

PHYS-2020: General Physics II

Problem Set 2, Spring 2012

There are 8 problems you are to complete via the web at

<http://capa.etsu.edu/>

You will gain access to this set by typing in your CAPA Student Number and CAPA ID which will be supplied to you. These problems will be graded and must be completed by 6:00 p.m. on Friday, February 24, 2012. **Start working on these problems immediately Don't wait until the last day to start them. One never knows when the network will go down, and you will not be able to use this as an excuse for not doing your CAPA problems.** As a matter of fact, there will be no allowed excuses for not doing your CAPA homework.

The following problems will not be graded, but should be done for review. These problems are from your textbook (College Physics, 9th Edition, Serway & Vuille). The solutions are posted on the course web page. **Try to work these problems out by yourself before looking at the solutions I have supplied for you.**

1. In the figure below, $\Delta V = 30 \text{ V}$, $R_1 = 12 \Omega$, $R_2 = 18 \Omega$, $R_3 = 9.0 \Omega$, and $R_4 = 6.0 \Omega$. Find the equivalent resistance of this circuit.

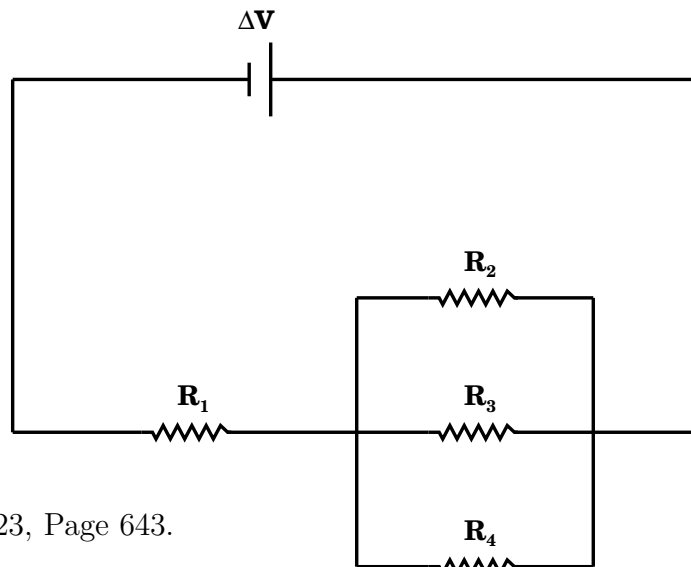

2. Problem 18.23, Page 643.
3. Problem 18.32, Page 644.
4. Problem 19.2, Page 679.

5. A proton travels with a speed of 3.0×10^6 m/s at an angle of 37° with the direction of the 0.30 T magnetic field in the $+y$ direction. What are (a) the magnitude of the magnetic force on the proton and (b) the proton's acceleration?
6. Problem 19.17, Page 680.
7. Problem 19.27, Page 681.
8. Problem 19.36, Page 682.
9. Problem 19.48, Page 683.
10. What current is required in the windings of a long solenoid that has 1000 turns uniformly distributed over a length of 0.400 m in order to produce a magnetic field of magnitude 1.00×10^{-4} T at the center of the solenoid?
11. Consider a place where Earth's magnetic field has strength of 0.520×10^{-4} T and makes an angle of 62.0° with the horizontal. At this location a magnetic compass points towards true north. What is the magnetic flux in a rectangular loop of wire that is 15.0 by 25.0 cm and is lying on a table? What is the magnetic flux in this loop if it is mounted vertically on a north wall? On an east wall?
12. A strong electromagnet produces a uniform field of 1.60 T over a cross-sectional area of 0.200 m^2 . We place a coil having 200 turns and a total resistance of 20.0Ω around the electromagnet. We then smoothly decrease the current in the electromagnet until it reaches zero in 20.0 ms. What is the current induced in the coil?
13. A jet with a wingspan of 60.0 m is flying horizontally at a speed of 300 m/s at an altitude of 1.98 km. At the location of the jet, the Earth's magnetic field is $50.0 \mu\text{T}$ pointing 58.0° below the horizontal. What voltage is generated between the wingtips as a result of these conditions?
14. Problem 20.34, Page 719.
15. A 2.00 H inductor carries a steady current of 0.500 A. When the switch in the circuit is thrown open, the current is effectively zero after 10.0 ms. What is the average induced emf in the inductor during this time?
16. A 6.0-V battery is connected in series with a resistor and an inductor. The series circuit has a time constant of $600 \mu\text{s}$, and the maximum current is 300 mA. What is the value of the inductance?
17. An air-core solenoid with 68 turns is 8.00 cm long and has a diameter of 1.20 cm. How much energy is stored in its magnetic field when it carries a current of 0.770 A?