

PHYS-2020: General Physics II
Course Lecture Notes
Section V

Dr. Donald G. Luttermoser
East Tennessee State University

Edition 3.3

Abstract

These class notes are designed for use of the instructor and students of the course **PHYS-2020: General Physics II** taught by Dr. Donald Luttermoser at East Tennessee State University. These notes make reference to the *College Physics, 9th Edition* (2012) textbook by Serway and Vuille.

V. Magnetism

A. Magnets.

1. Ancient people discovered a rock that when placed close to a similar rock, the rocks would move either closer or farther apart from each other \implies these rocks were called **loadstones** or **magnets**.
2. *Like poles* repel each other and *unlike* poles attract each other.
 - a) Magnets have to be asymmetrical for this to work \implies preferably the shape of a bar.
 - b) One pole is called **north** (N), the other **south** (S).
3. Like the electric field (\vec{E}), magnets have a **magnetic field** called the \vec{B} -field.

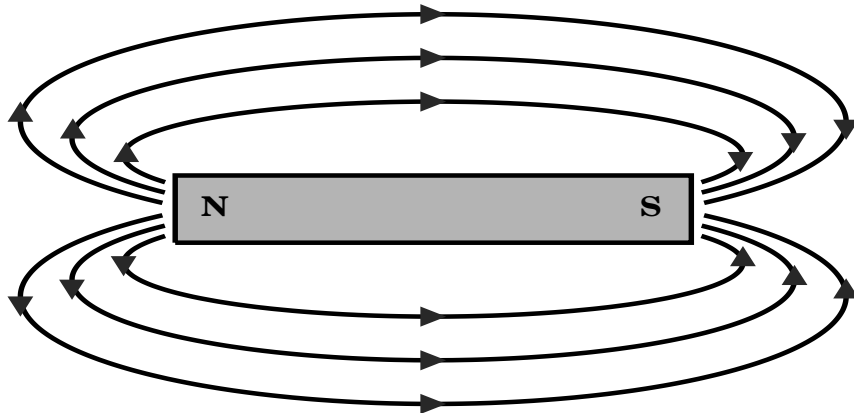

- a) The B -field points away from the north pole (hence is analogous to a + electric charge).
 - b) The B -field points towards from the south pole (hence is analogous to a - electric charge).
4. Unlike the electric field, there are no **monopoles** in magnetism \implies magnets are always **dipoles** (2 poles).

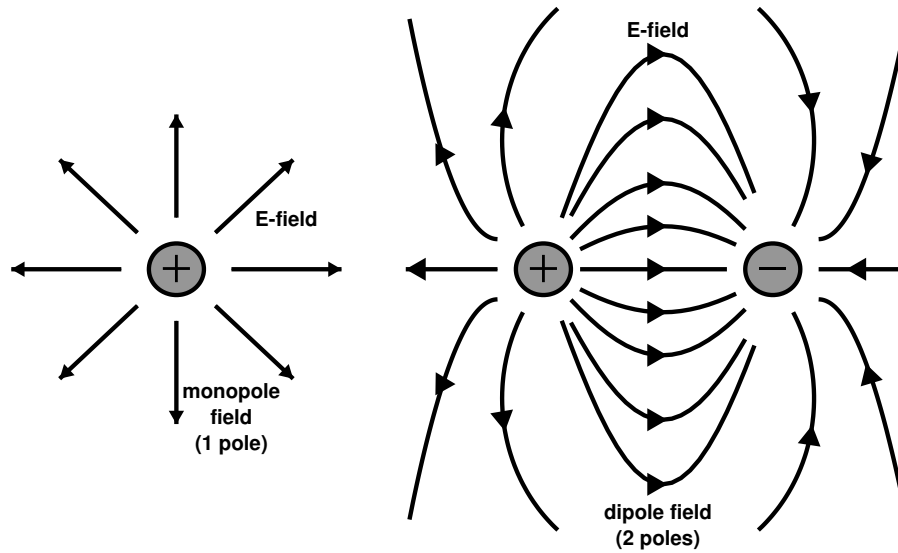

B. Magnetic Field of the Earth.

1. The Earth has a magnetic field!
 - a) Currently, the magnetic N pole corresponds to the S geographic pole (which is why your compass's N points to geographic N, remember, like poles repel, opposites attract).
 - b) The magnetic S pole corresponds to the N geographic pole.
 - c) The magnetic axis is not aligned with the spin axis!

2. Devices used to measure the direction of the magnetic field are called **compasses**. The designation 'N' and 'S' for either pole on a compass was assigned based on which end pointed to the Earth's north pole \implies 'N' *seeks* Earth's North pole.

3. The Earth's magnetic field is generated by electric currents in the liquid outer core of the planet which is composed of mostly nickel and iron. The electric currents arise from the Earth's rotation. The details of the geomagnetic field source is still not well understood.

4. The magnetic field of the Earth flips polarity (*i.e.*, reverses direction) in random intervals over time.
 - a) It has flipped 171 times over the past 76 million years. The average period between flips is about 10^4 to 10^5 years (with a peak average period of 200,000 years).
 - b) The last flip occurred 780,000 years ago.
 - c) We know this from the volcanic rocks near the Mid-Atlantic Ridge. As the sea-floor spreads as mantle material flows upward at that location, the rock solidifies when it hits the water. The metallic compounds in the lava “freeze” the direction of the magnetic field as the liquid lava turns to solid basalt rock.
 - d) Geomagnetic field measurements over the past few hundred years show that the B -field strength of the Earth is decreasing.
 - i) Today the Earth’s magnetic field is 10% weaker than it was when Carl Gauss started keeping tabs on it in 1845.
 - ii) We may be on our way to another polarity flip within the next few thousand years.

C. Magnetic Fields.

1. When moving through a magnetic field, a charged particle experiences a force.
 - a) The force has a maximum value when the charge moves \perp to the B -field lines.
 - b) The force becomes zero when the charge moves parallel to the field.

- c) This force is given by the equation:

$$\boxed{F = qvB \sin \theta} \quad (\text{V-1})$$

or

$$\boxed{B \equiv \frac{F}{qv \sin \theta}} \quad (\text{V-2})$$

- i) $F = F_B \equiv$ magnetic force.
- ii) $q \equiv$ electric charge of the particle moving in the B -field.
- iii) $v \equiv$ velocity of the particle.
- iv) $B \equiv$ strength of the magnetic field.
- v) $\theta \equiv$ angle between \vec{v} and \vec{B} .
- d) The SI units for magnetic field is **tesla** (T).
- i) The magnetic field is also measured in **weber (Wb) per square meter**:

$$1 \text{ T} = 1 \text{ Wb/m}^2 ,$$

where a weber is the unit of magnetic flux (see §VI of the notes).

- ii) Units of B :

$$[B] = \text{T} = \frac{\text{Wb}}{\text{m}^2} = \frac{\text{N}}{\text{C}\cdot\text{m/s}} = \frac{\text{N}}{\text{A}\cdot\text{m}} .$$

- iii) Note that the cgs units for magnetic field strength is still widely used — especially in astronomy and geology \implies the **gauss** (G).

$$1 \text{ T} = 10^4 \text{ G} .$$

Also note that the magnetic flux in the cgs system is the **maxwell** (Mx), where $1 \text{ G} = 1 \text{ Mx/cm}^2$ and $1 \text{ Mx} = 10^{-8} \text{ Wb}$.

- iv) Laboratory magnets can reach as high as 25,000 G = 2.5 T. The Earth's magnetic field is about 0.5 G.

2. Though we wrote Eqs. (V-1) and (V-2) as scalar equations, in reality, they are *3-dimensional* vector equations $\implies \vec{F}$ is always in a direction that is \perp to the plane defined by the \vec{v} and \vec{B} vectors. (In upper-level physics, $\vec{F} = q\vec{v} \times \vec{B}$, a vector cross product.)

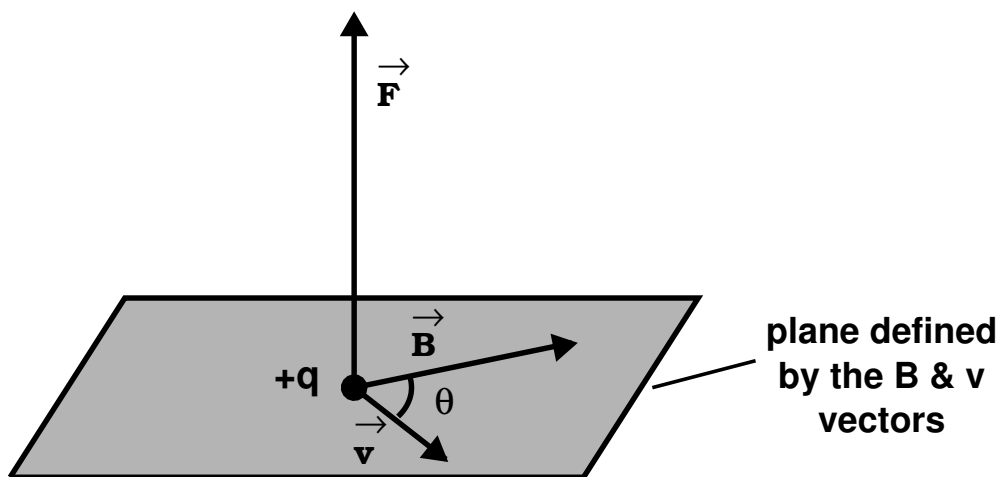

- a) The maximum force on a charged particle traveling through a B -field is

$$F_{\max} = qvB , \quad (\text{V-3})$$

This will only occur when the \vec{F} , \vec{B} , and \vec{v} are all \perp to each other.

- b) The **right-hand rule** is used to see which direction \vec{F} points with respect to vectors \vec{B} and \vec{v} :

- i) For a positive charge, treat \vec{v} as the reference vector and curl the fingers of your right hand towards \vec{B} keeping your thumb pointing out from your hand. The direction your thumb is pointing is the direction of \vec{F} .
- ii) For a negative charge, do as above but swap \vec{v} with \vec{B} so that \vec{B} is now the “reference” vector.

Example V-1. Problem 19.11 (Page 680) from the Serway & Vuille textbook: At the Equator near the Earth’s surface, the magnetic field is approximately $50.0 \mu\text{T}$ northward and the electric field is about 100 N/C downward in fair weather. Find the gravitational, electric, and magnetic forces on an electron with an instantaneous velocity of $6.00 \times 10^6 \text{ m/s}$ directed to the east in this environment. *Added question:* What is the total force on the electron and what is the final acceleration on the electron?

Solution:

Let’s define \hat{z} as the unit vector in the upward direction, \hat{x} in the East direction, and \hat{y} in the North direction. The mass of an electron is $m_e = 9.11 \times 10^{-31} \text{ kg}$ and the charge is $e = -1.60 \times 10^{-19} \text{ C}$. The various forces are then equal to the following:

For the **gravitational force**, \vec{g} points downward, opposite to the \hat{z} direction, therefore

$$\begin{aligned}\vec{F}_g &= m\vec{g} = m(-g)\hat{z} = (9.11 \times 10^{-31} \text{ kg})(-9.80 \text{ m/s}^2)\hat{z} \\ &= \boxed{-8.93 \times 10^{-30} \text{ N } \hat{z} ,}\end{aligned}$$

or in the downward direction.

For the **electric force**, \vec{E} points downward, opposite the \hat{z} direction, therefore,

$$\begin{aligned}\vec{F}_e &= q\vec{E} = (-e)(-E)\hat{z} = (-1.60 \times 10^{-19} \text{ C})(-100 \text{ N/C})\hat{z} \\ &= \boxed{1.60 \times 10^{-17} \text{ N } \hat{z} ,}\end{aligned}$$

or in the upward direction.

For the **magnetic force**, \vec{v} points eastward in the positive \hat{x} direction and \vec{B} points northward in the positive \hat{y} direction. Using the right-hand rule for a negative charge we choose \vec{B} as the reference vector and curl it into \vec{v} . Doing this, we curl our fingers from North to East and our right thumb points in the downward direction, hence negative \hat{z} . Since we have used the right-hand rule to determine our direction, we will just use the absolute value of our quantities in Eq. (V-1). Since $\vec{B} \perp \vec{v}$, $\theta = 90^\circ$, so

$$\begin{aligned}\vec{F}_B &= -|q||v||B|\sin\theta\hat{z} \\ &= -(1.60 \times 10^{-19} \text{ C})(6.00 \times 10^6 \text{ m/s})(50.0 \times 10^{-6} \text{ T})\sin 90^\circ\hat{z} \\ &= \boxed{-4.80 \times 10^{-17} \text{ N } \hat{z} ,}\end{aligned}$$

or in the downward direction.

We can now calculate the total force on this electron as

$$\begin{aligned}\vec{F}_{\text{tot}} &= \vec{F}_g + \vec{F}_e + \vec{F}_B \\ &= (-8.93 \times 10^{-30} \text{ N})\hat{z} + (1.60 \times 10^{-17} \text{ N})\hat{z} + \\ &\quad (-4.80 \times 10^{-17} \text{ N})\hat{z} \\ &= \boxed{-3.20 \times 10^{-17} \text{ N } \hat{z} ,}\end{aligned}$$

or the electron moves downward with an acceleration of

$$\begin{aligned}\vec{a} &= \frac{\vec{F}_{\text{tot}}}{m_e} = \frac{(-3.20 \times 10^{-17} \text{ N})\hat{z}}{9.11 \times 10^{-31} \text{ kg}} \\ &= \boxed{(-3.51 \times 10^{13} \text{ m/s}^2)\hat{z} = -3.58 \times 10^{12} g \hat{z} ,}\end{aligned}$$

or 3.58 trillion surface gravities! Note that the gravitational force is negligible with respect to the electric and the magnetic forces in the above calculation of the total force.

D. Magnetic Force on a Current-Carrying Conductor.

1. A current-carrying wire also experiences a force if it passes through a magnetic field.
2. Inside the wire, charges are moving along the length of the wire “ l .”

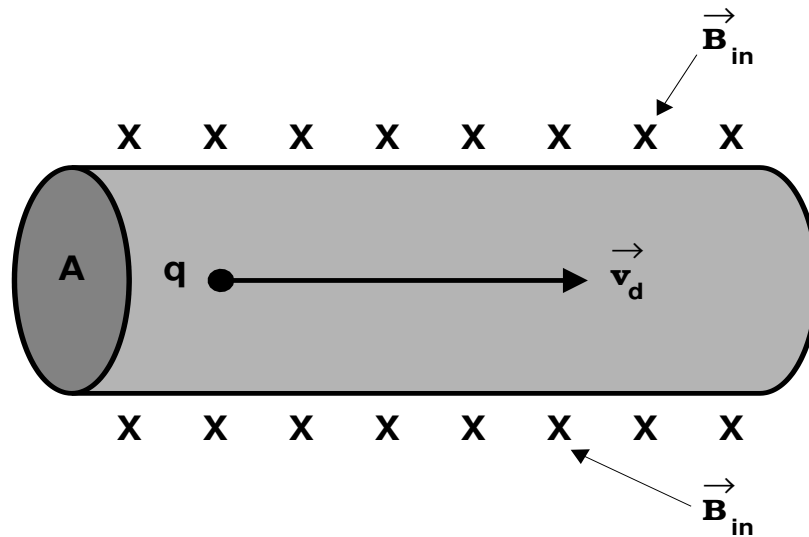

3. The total force F_{tot} acting on the wire will be equal to the sum of all of the forces on the individual charges F_{ind} flowing in the wire:

$$F_{\text{tot}} = N F_{\text{ind}} , \quad (\text{V-4})$$

where N is the number of charges in the wire. Since on average all of the charges are moving in the same direction, the total force will be the same direction as the average forces on the individual particles.

- a) The number of charges in the wire (a unitless number) is determined with

$$N = n A \ell , \quad (\text{V-5})$$

where n is the particle density of charges [m^{-3}], A is the cross-sectional area of the wire [m^2], and ℓ is the length of the wire [m].

- b) The forces on the individual particles is just determined from Eq. (V-1):

$$F_{\text{ind}} = q v_d B \sin \theta , \quad (\text{V-6})$$

where v_d is the drift velocity of the charges in the wire given by Eq. (III-6) and \vec{v}_d points in the same direction as $\vec{\ell}$.

- c) If the B -field is \perp to the length of the wire:

$$\begin{aligned} F_{\text{max-tot}} &= (q v_d B \sin 90^\circ)(n A \ell) \\ &= (q v_d B)(n A \ell) , \end{aligned}$$

but $I = n q v_d A$ (see Eq. III-5), so

$$F_{\text{max-tot}} = (n q v_d A)(B \ell)$$

or

$$\boxed{F_{\text{max}} = B I \ell .} \quad (\text{V-7})$$

- d) If the B -field is in some arbitrary direction with respect to the length of the wire, hence current, then

$$\boxed{F = B I \ell \sin \theta ,} \quad (\text{V-8})$$

where θ is the angle between the \vec{B} vector and the $\vec{\ell}$ vector.

- e) For this force equation, the direction of \vec{F} with respect to \vec{B} and $\vec{\ell}$ is found from the right-hand rule following what

was written for a point charge, however, here we use ‘ $I\vec{\ell}$ ’ in place of ‘ \vec{v} .’ Since I is automatically defined as the direction that positive charge flows, we take with $I\vec{\ell}$ as the reference vector and “curl” it towards \vec{B} . Your right thumb then indicates the direction of \vec{F} .

4. This is how speakers work, a current is passed through a wire wrapped around a magnet and the wire is connected to a diaphragm (usually paper in cheaper speakers) surrounded by a cone (to direct the sound waves).
 - a) As the current is turned on and off in the wire, the wire continuously “feels” a force cycle between an “on” and “off” state \implies causes the wire to move back and forth.
 - b) Since the coil is connected to the diaphragm, the diaphragm moves as well causing sound waves to form.
 - c) The sound propagates in the direction that the cone is pointing (see Figure 19.13 in your textbook).

Example V-2. A wire carries a steady current of 2.40 A. A straight section of the wire is 0.750 m long and lies along the x axis within a uniform magnetic field of magnitude 1.60 T in the positive z direction. If the current is in the $+x$ direction, what is the magnitude of the force on the section of the wire?

Solution:

Here, $\vec{B} = B\hat{z}$ and $\vec{\ell} = L\hat{x}$, with $B = 1.60$ T and $L = 0.750$ m. Curling $\vec{\ell}$ into \vec{B} has our right thumb pointing in the $-y$ direction (*i.e.*, $-\hat{y}$). The magnitude of the force is found with Eq. (V-8) with $\theta = 90^\circ$ (the angle between $\vec{\ell}$ and \vec{B}):

$$F = BIL \sin \theta = (1.60 \text{ T})(2.40 \text{ A})(0.750 \text{ m}) \sin 90^\circ = 2.88 \text{ N} .$$

Using this magnitude with the above derived direction gives us a magnetic force vector of

$$\vec{F} = -2.88 \text{ N } \hat{y} .$$

E. Torque on a Current Loop: Galvanometers and Electric Motors.

1. Consider a rectangular loop carrying current I in the presence of an external B -field in the plane of the loop:

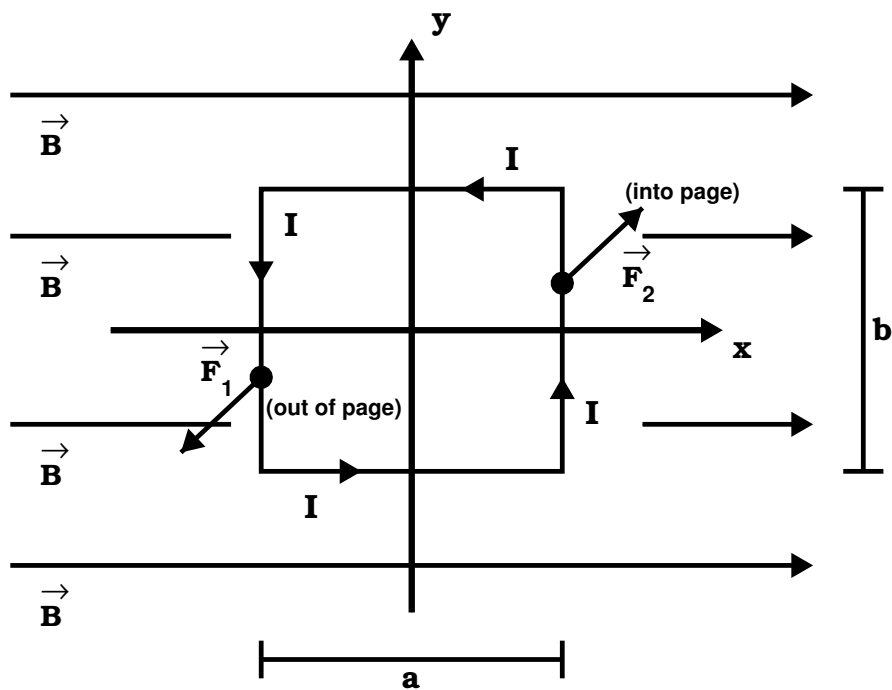

- a) Forces on the 'a' lengths are zero in the diagram above since $\vec{B} \parallel \vec{\ell}$ ($\vec{\ell} \equiv$ length).
- b) Forces on the 'b' lengths are

$$|\vec{F}_1| = |\vec{F}_2| = BIb . \quad (\text{V-9})$$

2. Viewing this loop on its side (rotated about the x axis) gives:

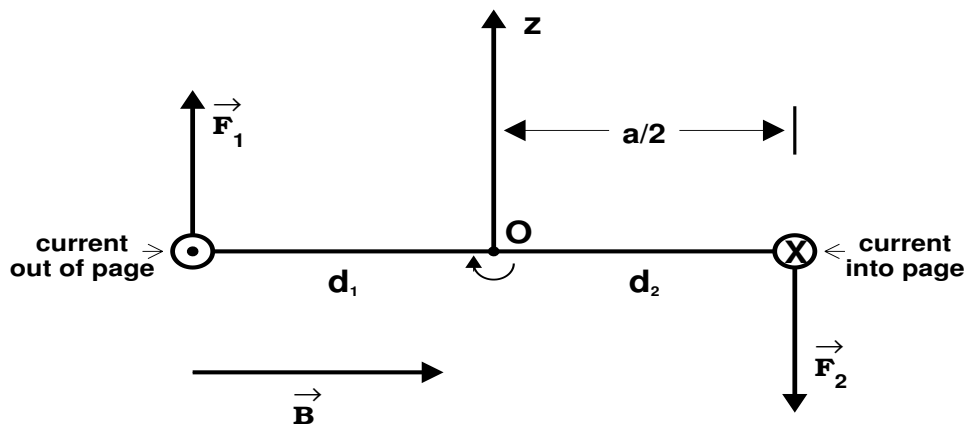

- a) From this viewpoint, let's rotate the loop about the origin O (and about the y axis above).
- b) The magnitude (hence a positive number) of the maximum torque that will occur on the loop will take place when I is *farthest* from the z axis (*i.e.*, $a/2$ as drawn above).

$$\begin{aligned}\tau_{\max} &= F_1 d_1 + F_2 d_2 = F_1 \frac{a}{2} + F_2 \frac{a}{2} \\ &= (BIb) \frac{a}{2} + (BIb) \frac{a}{2} = B I a b\end{aligned}$$

- c) Since the area of the loop is $A = ab$, we see that

$$\boxed{\tau_{\max} = B I A .} \quad (\text{V-10})$$

3. If we let the loop rotate about the y axis, then

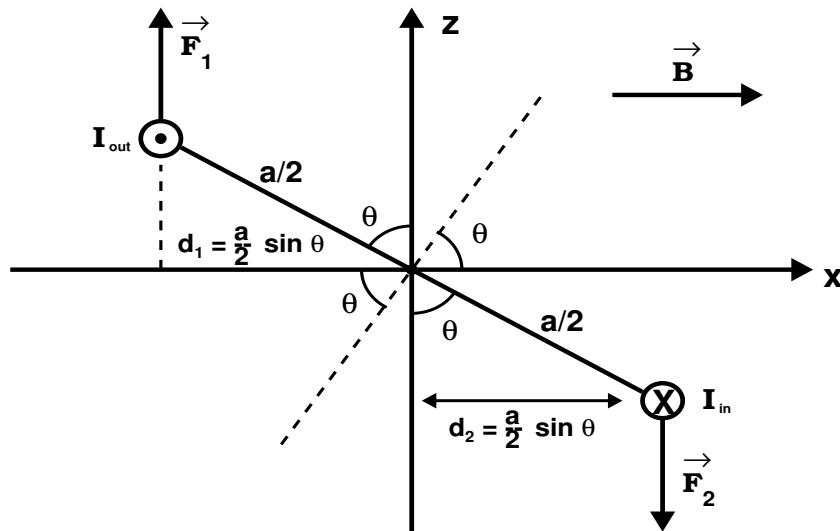

$$\tau = BIA \sin \theta . \quad (\text{V-11})$$

4. If we have more than 1 loop in the B field \implies *i.e.*, a “loop” with N “turns,” we get

$$\tau = NBIA \sin \theta . \quad (\text{V-12})$$

Example V-3. Problem 19.26 (Page 681) from the Serway & Vuille textbook: A current of 17.0 mA is maintained in a single circular loop with a circumference of 2.00 m. A magnetic field of 0.800 T is directed parallel to the plane of the loop. What is the magnitude of the torque exerted by the magnetic field on the loop?

Solution:

The magnitude of torque for a single loop in a magnetic field is given by Eq. (V-11) [or Eq. (V-12) by setting $N = 1$]. Here, θ is the angle between the field and the normal line of the plane defined by the loop. The B -field is parallel to the loop, hence

plane, so $\theta = 90^\circ$ since the normal (\perp) line of the loop plane is at a right angle to the B -field.

We now need to determine the cross-sectional area of the loop. The circumference of the loop is given as $C = 2\pi r = 2.00$ m. From this we can calculate the area of the loop as follows:

$$r = \frac{C}{2\pi} = \frac{2.00 \text{ m}}{2\pi} = \frac{1.00}{\pi} \text{ m}$$

$$A = \pi r^2 = \pi \left(\frac{1.00}{\pi} \text{ m} \right)^2 = \frac{1.00}{\pi} \text{ m}^2 .$$

We can now calculate the magnitude of the torque from Eq. (V-11):

$$\begin{aligned} \tau &= B I A \sin \theta \\ &= (0.800 \text{ T})(17.0 \times 10^{-3} \text{ A}) \left(\frac{1.00}{\pi} \text{ m}^2 \right) \sin 90.0^\circ \\ &= \boxed{4.33 \times 10^{-3} \text{ N}\cdot\text{m} .} \end{aligned}$$

5. Galvanometers use torque due to an internal magnetic field to deduce current in an electric circuit.

- a) When current passes through the coil of a galvanometer situated in a B -field (produced by two permanent magnets inside the galvanometer), the magnetic torque causes the coil to twist. The angle through which the coil rotates \propto current through it.
- b) A needle (*i.e.*, indicator) is connected to the coil which points at a calibrated scale \implies the needle's motion indicates the amount of current.

6. Likewise, passing a current through a loop embedded in a magnetic field, can impart a torque on the loop which causes the loop to rotate \implies an **electric motor**.
 - a) The current cannot be allowed to continue in the same direction since once the loop rotates through the $\theta = 0$ configuration, the force goes to zero at that point.
 - b) Once the loop rotates past this direction (due to its inertia), the torque acts to slow the motion (*i.e.*, the force reverses direction) causing the rotation to stop.
 - c) A continuous rotation can be maintained if the direction of the current changes every half rotation. This can be accomplished automatically if using an **alternating current** (AC) — what your wall outlets deliver.
 - d) A direct current (DC) can be used if the current can be made to change direction in the motor itself \implies this is accomplished mechanically in such DC electric motors with split-ring contacts called *commutators* and *brushes* as shown in Figure 19.17 in the textbook.

F. Motion of a Charged Particle in a B -Field.

1. Assume a charged particle (+ charge) moves \perp to a B -field.
 - a) Since the force on the particle follows the right-hand rule, $\vec{F} \perp \vec{B}$ and $\vec{F} \perp \vec{v} \implies$ the particle is forced to move in a circular path!
 - b) The magnitude of the force always points towards the center of the circular path.

- c) If \vec{v} is not perpendicular to \vec{B} , the particle moves in a helical path along the field lines:

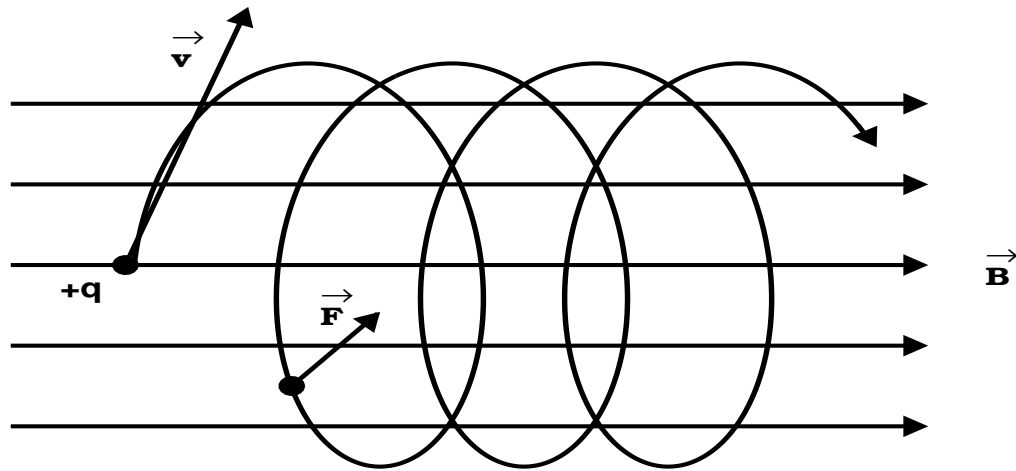

2. Since the particle is in circular motion, there must be a centripetal force (*i.e.*, the magnetic force) on the particle:

$$F = qvB = \frac{mv^2}{r} . \quad (\text{V-13})$$

- a) Here, $F_c = mv^2/r$ is the centripetal force.
- b) The **radius of curvature** of the path is then

$$\boxed{r = \frac{mv}{qB} .} \quad (\text{V-14})$$

Example V-4. A cosmic-ray proton in interstellar space has an energy of 10.0 MeV and executes a circular orbit having a radius equal to that of Mercury's orbit around the Sun (5.80×10^{10} m). What is the magnetic field in that region of space?

Solution:

Since the path is circular, the particle moves \perp to the B -field, hence the magnetic force supplies the centripetal acceleration, so

$$F_c = F_B$$

$$m \frac{v^2}{r} = qvB$$

$$B = \frac{mv}{qr} .$$

From General Physics I, we can write the linear momentum of this proton as

$$p = mv = \sqrt{2m(\text{KE})} ,$$

and the kinetic energy (KE) of this proton is 10.0 MeV. Converting this to Joules gives

$$\text{KE} = (10.0 \times 10^6 \text{ eV}) \left(\frac{1.60 \times 10^{-19} \text{ J}}{1 \text{ eV}} \right) = 1.60 \times 10^{-12} \text{ J} .$$

Noting that the mass of a proton is $m = 1.67 \times 10^{-27} \text{ kg}$ and the charge of a proton is $q = e = 1.60 \times 10^{-19} \text{ C}$, we now have all we need to determine the B -field from the equation above:

$$B = \frac{mv}{qr} = \frac{p}{qr} = \frac{\sqrt{2m(\text{KE})}}{qr}$$

$$= \frac{\sqrt{2(1.67 \times 10^{-27} \text{ kg})(1.60 \times 10^{-12} \text{ J})}}{(1.60 \times 10^{-19} \text{ C})(5.80 \times 10^{10} \text{ m})}$$

$$= \boxed{7.88 \times 10^{-12} \text{ T} .}$$

G. Ampere's Law.

1. If a wire is grasped in the right hand with the thumb pointing in the direction of the current, the fingers will curl in the direction of $\vec{B} \implies$ **right hand rule for wires.**

a) Hans Oersted figured this out in 1819.

- b) The B -field curves around a straight wire carrying a current.

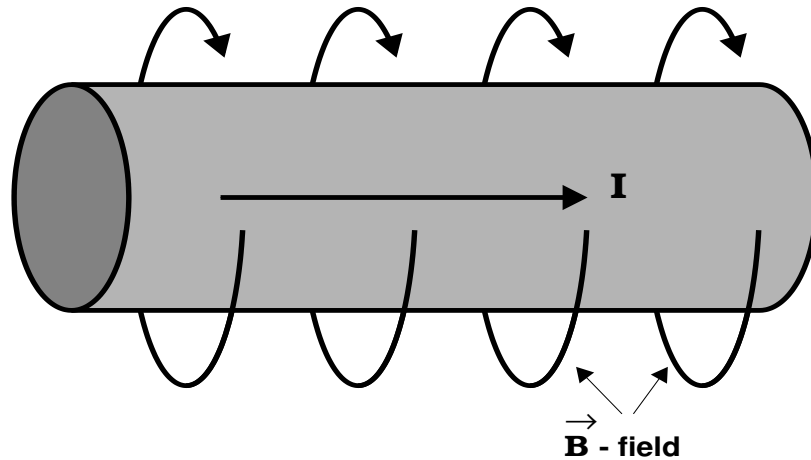

- c) Shortly after Oersted's discovery, scientists determined the following relation between the strength of the B -field and the current in a wire:

$$\boxed{B = \frac{\mu_0 I}{2\pi r}} \quad (\text{V-15})$$

- i) $r \equiv$ distance (\perp) from wire.
- ii) $\mu_0 \equiv$ permeability of free space:

$$\mu_0 = 4\pi \times 10^{-7} \text{ T m/A} .$$

2. Ampere's Circuit Law:

$$\boxed{\sum B_{\parallel} \Delta \ell = \mu_0 I ,} \quad (\text{V-16})$$

which is the algebraic form of the more general calculus form given by

$$\oint \vec{B} \cdot d\vec{\ell} = \mu_0 I ,$$

where the ' \oint ' symbol means *line integral* and ' $d\ell$ ' means an infinitesimally small segment of the closed path we are integrating (or summing) over.

- a) $\sum B_{\parallel} \Delta\ell$ means that we take the sum over all products $B_{\parallel} \Delta\ell$ around a closed path.
- b) B_{\parallel} is the B -field component that is tangential to the B -field circular path.
- c) $\Delta\ell$ is a path segment along the B -field.
- d) This law (Eq. V-16) is usually just referred to as Ampere's law. It is one of the basic equations of electromagnetism.

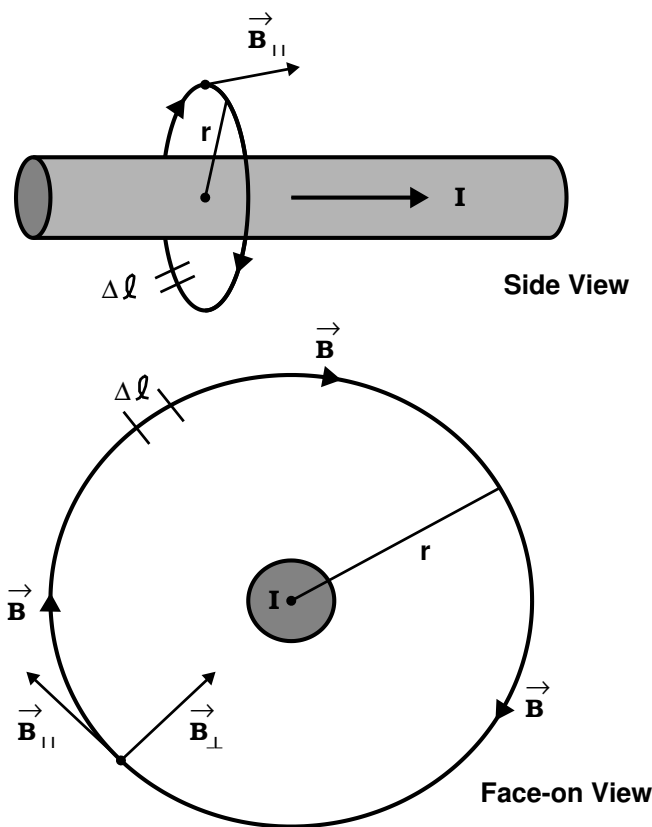

3. We can now use Ampere's circuit law to derive Eq. (V-15), Ampere's general law.

- a) Starting with Eq. (V-16), we see that since B is perfectly circular around a wire, B_{\parallel} is uniform along $\Delta\ell$:

$$B_{\parallel} \sum \Delta\ell = \mu_0 I .$$

- b) $\Delta\ell$ is just individual segments of the complete circle defined by $B \implies$ summing up all of these segments around the entire circle is just the circumference of the circle:

$$\sum \Delta\ell = C = 2\pi r$$

so

$$B_{\parallel}(2\pi r) = \mu_0 I$$

or

$$B_{\parallel} = B = \frac{\mu_0 I}{2\pi r}$$

which is Eq. (V-15)!

4. We can now bring 2 wires close together and calculate the effect of one of the wire's B field on the other.

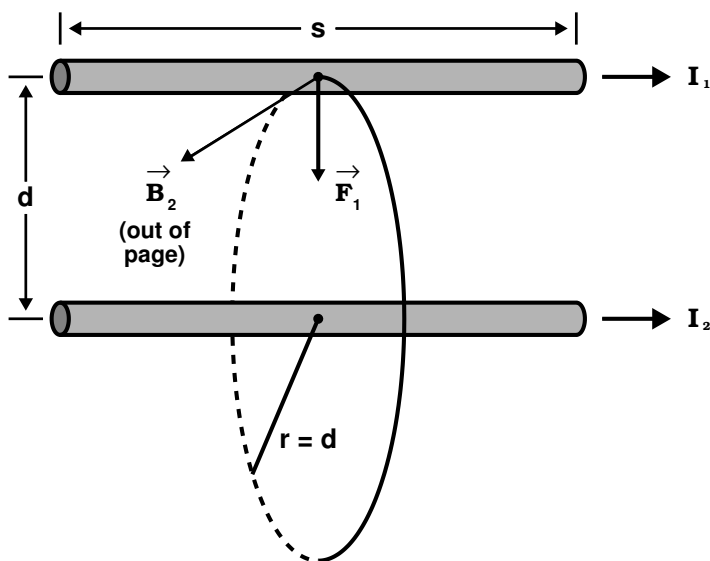

- a) For wire 2 located a distance d from wire 1:

$$B_2 = \frac{\mu_0 I_2}{2\pi d} .$$

- b) The force on wire 1 from B_2 is given by Eq. (V-7):

$$F_1 = B_2 I_1 s = \left(\frac{\mu_0 I_2}{2\pi d} \right) I_1 s = \frac{\mu_0 I_1 I_2 s}{2\pi d} ,$$

where s is the length of a given segment in the line.

- c) We can rewrite this as the force per unit length:

$$\boxed{\frac{F_1}{s} = \frac{\mu_0 I_1 I_2}{2\pi d}} \quad (\text{V-17})$$

5. The force between 2 parallel wires carrying a current is used to define the SI units of current \implies ampere (A).
- a) If 2 long \parallel wires 1 meter apart carry the same current, and the force/length on each wire is 2.0×10^{-7} N/m, then the current is defined to be 1.0 A.
- b) If a conductor carries a steady current of 1.0 A, then through any cross-section of wire, 1.0 C of charge passes by every second.

Example V-5. A long straight wire lies on a horizontal table and carries a current of $1.20 \mu\text{A}$. In a vacuum, a proton moves parallel to the wire (opposite the current) with a constant velocity of 2.30×10^4 m/s at a constant distance d above the wire. Determine the value of d . You may ignore the magnetic field due to the Earth.

Solution:

Since the proton moves at constant velocity, the net force acting on it is zero. Since the current carrying wire produces a B -field, it will supply a force on the proton. Also, this force will be pointing upward ($+z$ direction) as dictated from the right-hand rule, since the proton is moving opposite to the current and \vec{B} points \perp to the wire (hence \vec{v}) and parallel to the table top. As such, there must be some counterbalancing force, pointing downward, that also is acting on the proton to keep the net force zero. Since we are ignoring the \oplus 's B -field, the only other force available is the gravitational force acting on the proton from the \oplus (which points

downward just as we need). Hence, we have

$$\begin{aligned} F_B &= F_g \\ qvB &= mg \\ B &= \frac{mg}{qv} . \end{aligned}$$

The B -field is being generated by the current I in the wire, as such, we also can use Eq. (V-15) to determine B with $r = d$ for our case here:

$$B = \frac{\mu_0 I}{2\pi d} .$$

Solving these two simultaneous equations for d gives

$$\begin{aligned} \frac{mg}{qv} &= \frac{\mu_0 I}{2\pi d} \\ d &= \frac{qv\mu_0 I}{2\pi mg} = \left[\frac{qv}{2\pi mg} \right] \mu_0 I \\ &= \left[\frac{(1.60 \times 10^{-19} \text{ C})(2.30 \times 10^4 \text{ m/s})}{2\pi(1.67 \times 10^{-27} \text{ kg})(9.80 \text{ m/s}^2)} \right] \times \\ &\quad (4\pi \times 10^{-7} \text{ T}\cdot\text{m/A})(1.20 \times 10^{-6} \text{ A}) \\ &= 5.40 \times 10^{-2} \text{ m} = \boxed{5.40 \text{ cm}} . \end{aligned}$$

H. Solenoids.

1. A **solenoid** is a device that produces a dipole magnetic field from electricity flowing through a coil of wire.
2. Solenoids also are called **electromagnets**.
3. The strength of the B -field inside the solenoid (where the field is relatively parallel) is given by

$$\boxed{B = \mu_0 n I} , \quad (\text{V-18})$$

where $n = N/\ell$ is the number of turns in the coil per unit length.

- a) We can derive the solenoid equation (Eq. V-18) through Ampere's law as follows. Consider the B -field of an infinitely long solenoid. The B -field inside this solenoid is uniform and parallel to the axis of the solenoid.
- b) The B -field outside the infinite solenoid is zero since the field lines can never leave an infinitely long cylinder. As such, we can set $B = 0$ on the outside.
- c) Taking a rectangular path in our closed loop through one side of the solenoid as shown in Figure 19.35 in the text-book, the sides of the rectangle that are \perp ($\theta = 90^\circ$) to the B -field produce no terms in the sum of Eq. (V-16) since $\vec{B} \cdot \Delta\vec{\ell} = B \Delta\ell \cos \theta = B \Delta\ell \cos 90^\circ = 0$.
- d) Since $B = 0$ outside the solenoid, $B \Delta\ell = 0$ on that side of the rectangle, independent of the fact that $\theta = 0^\circ$ for that part of the loop.
- e) As such, the only side that has a non-zero value is the one interior to the solenoid. If we set the length of that side to L , we can rewrite the sum in Eq. (V-16) as

$$\sum B_{\parallel} \Delta\ell = BL .$$

- f) Using this in Eq. (V-16), we can write

$$BL = \mu_0 NI ,$$

where here we have to introduce N , the number of turns in length L , since the current I in Eq. (V-16) is the total of all currents in a given closed loop.

- g) Since $n = N/L$, we can now write

$$B = \mu_0 \frac{N}{L} I = \mu_0 n I ,$$

which is Eq. (V-18).

Example V-6. Problem 19.61 (Page 685) from the Serway & Vuille textbook: It is desired to construct a solenoid that has a resistance of 5.00Ω (at 20°C) and that produces a magnetic field of at its center of $4.00 \times 10^{-2} \text{ T}$ when it carries a current of 4.00 A . The solenoid is to be constructed from copper wire having a diameter of 0.500 mm . If the radius of the solenoid is to be 1.00 cm , determine (a) the number of turns of the wire needed and (b) the length the solenoid should have.

Solution (a):

Using Eq. (III-10), with $\rho = 1.70 \times 10^{-8} \Omega \cdot \text{m}$ for copper (from Table 17.1 from the textbook), the required length of wire to be used is

$$\begin{aligned} R &= \rho \frac{L}{A} \\ L &= \frac{RA}{\rho} = \frac{R(\pi D^2/4)}{\rho} \\ &= \frac{(5.00 \Omega) \left[\pi (0.500 \times 10^{-3} \text{ m})^2 / 4 \right]}{1.70 \times 10^{-8} \Omega \cdot \text{m}} \\ &= 57.7 \text{ m} . \end{aligned}$$

The total number of turns on the solenoid (*i.e.*, the number of times this length of wire will go around a 1.00 cm radius cylinder) is

$$N = \frac{L}{C} = \frac{L}{2\pi r} = \frac{57.7 \text{ m}}{2\pi(1.00 \times 10^{-2} \text{ m})} = \boxed{919} .$$

Solution (b):

From $B = \mu_0 n I$, the number of turns per unit length on the solenoid is

$$\begin{aligned} n &= \frac{B}{\mu_0 I} \\ &= \frac{4.00 \times 10^{-2} \text{ T}}{(4\pi \times 10^{-7} \text{ T} \cdot \text{m/A})(4.00 \text{ A})} \end{aligned}$$

$$= 7.96 \times 10^3 \text{ turns/m} .$$

Thus, the required length for the solenoid is

$$L_s = \frac{N}{n} = \frac{919 \text{ turns}}{7.96 \times 10^3 \text{ turns/m}} = 0.115 \text{ m} = \boxed{11.5 \text{ cm} .}$$

I. Magnetic Domains.

1. As we now have seen, electric currents traveling in curved paths produce a magnetic field.
 - a) It is electric currents in the hot, ionized, liquid Ni-Fe core of the Earth that produces its dipole magnetic field.
 - b) Since electrons are in “orbit” around the nucleus of an atom, individual atoms also produce their own internal magnetic field.

2. The orientation of the B -fields generated by individual atoms is generally random \implies the magnetic effect produced by the electrons orbiting the nucleus is either zero or very small in most materials.

3. Besides orbiting the nucleus, electrons also have an intrinsic spin which also produces a magnetic field.
 - a) Typically the orientations of these spin B -fields are random too producing no net B -field to the macroscopic world — most substances are not magnets.
 - b) However, certain strongly magnetic materials such as iron (Fe), cobalt (Co), and nickel (Ni), have electron spin magnetic fields that do not completely cancel out \implies these

materials are called **ferromagnetic** ('ferro' from the Latin name for iron).

- c) In ferromagnetic materials, strong coupling occurs between neighboring atoms, forming large groups of atoms called **domains** in which the spins are aligned.
 - d) In unmagnetized substances, the domains are randomly oriented. But when an external field is applied, many of the domains line up with the external field \implies this causes the material to become magnetized.
4. Materials that can retain a macroscopic magnetic field after they have been *pumped* by an external magnetic field are called *hard magnetic materials* \implies **permanent magnets**.
 5. Those materials that lose their magnetic field once the external magnet is removed are called *soft magnetic materials* (Fe and Ni are examples). The unalignment of the magnetic domains occur due to thermal motions of the atoms in the domains.