



---

# INFORMATION TECHNOLOGY SERVICES

---

EAST TENNESSEE STATE UNIVERSITY

## CABLING INSTALLATION STANDARD

**APRIL 2023 - EDITION 4.0**

---

## PURPOSE

---

The ETSU ITS *Cabling Installation Standard (CIS)* is for use by installers to help ensure the successful implementation of all ICT/communications cabling and passive cabling components being installed. Cabling systems at ETSU are vendor-neutral and standards-based. This document is intended to answer FAQ of ETSU ITS' installation practices and not as a substitute for knowledge of industry accepted practices, specifications, standards or codes. The CIS is not project specific. While this document incorporates strategies to address adaptability, it is not possible to foresee all circumstances encountered in installation. The purpose of the CIS is to describe and specify the minimum acceptable methods of cabling installation and related components. The CIS is intended to be simultaneously used with ETSU-Facilities *Communications Design Standard* that can be found at: <https://www.etsu.edu/facilities/infrastructure.php> All installations shall be done by licensed, certified, insured and experienced professionals. The installer has the responsibility of providing an end product in compliance with ITS standards using accepted best practices as detailed in this document. ETSU-ITS requires BICSI certified professionals as well as manufacturer-certified installers for all work. In many cases the need will arise to consult with designers/engineers from other trades or areas of expertise. The CIS is based on the TIA *Commercial Building Telecommunications Standards* series as applies to cabling installation and has adopted the *BICSI Information Technology Systems Installation Methods Manual (ITSIMM latest edition)* as the basis for implementation of those standards at ETSU.

For references to units of measure, abbreviations, terms and definitions in this document please refer to BICSI's ICT Terminology Handbook available at <https://www.bicsi.org> or download [here](#).

---

## REVISIONS AND ERRATA

---

Although the goal is to review and revise this document every few years, changes in policy and technology can dictate that a revision is necessary with lesser or greater frequency. It is the responsibility of the user to ensure that the latest revision is being used.

Edition	Date of Issue
4.0 (revamped current edition)	April 2023

 The vertical line in the left margin indicates a revision from prior editions.

---

## GENERAL CONTACT INFORMATION FOR ETSU-ITS

---

Assistant CIO for Networking and Classrooms <i>Rob Nelson</i> (423)439-8365 <a href="mailto:nelsonr@etsu.edu">nelsonr@etsu.edu</a>	ITS Project Manager <i>Candy Massey</i> (423)439-4101 <a href="mailto:MASSEYC@etsu.edu">MASSEYC@etsu.edu</a>
Manager of Special Projects (Audio/Video) <i>Tim Ferguson</i> (423)439-4132 <a href="mailto:fergusot@etsu.edu">fergusot@etsu.edu</a>	Network Engineer <i>Tim White</i> (423)439-3601 <a href="mailto:whitet@etsu.edu">whitet@etsu.edu</a>
Customer Support Specialist <i>Borce Lazarov</i> (423)439-4104 <a href="mailto:borce@etsu.edu">borce@etsu.edu</a>	Telecommunications Coordinator <i>Woody Wolff</i> (423)439-7019 <a href="mailto:WOLFFWJ@etsu.edu">WOLFFWJ@etsu.edu</a>

Additional information on ETSU-ITS policies, procedures and projects can be found at: <https://www.etsu.edu/its/default.php>. All contractors and installers should familiarize themselves with these and other governing policies, including all applicable ETSU policies and those of Facilities Management, for all work at ETSU.

ETSU Information Technology Services  
PO Box 70728  
Nicks Hall 4<sup>th</sup> Floor  
356 Stout Drive  
Johnson City, TN 37614  
(423)439-7000

---

## CONTENTS

---

SECTION 1 – Installer Responsibilities and Procedures	3
SECTION 2 – Codes, Standards and Authorities Having Jurisdiction	5
SECTION 3 – Telecommunication Rooms and Spaces	6
SECTION 4 – Outside Plant (OSP): Conduit, Pathways, Spaces and Cabling	8
SECTION 5 – Inside Plant (ISP): Cable Tray, Conduit, Supports and Cabling	11
SECTION 6 – Specialty Systems and Procedures	16
SECTION 7 – Fire Stopping	20
SECTION 8 – Furniture, Fixtures and Equipment (FF&E)	20
SECTION 9 – Bonding and Grounding	21
SECTION 10 – Cable Testing and Documentation	22
SECTION 11 – Submittal Requirements / Shop Drawings	26
SECTION 12 – Labeling	27
Appendix A – Submittals Checklist	28
Appendix B – Standards Variance Form	29
Appendix C – Warranty Registration (sample)	31

---

## SECTION 1 - INSTALLER RESPONSIBILITIES AND PROCEDURES

---

All installers should incorporate the methods and best practices detailed herein, into all installations at ETSU facilities. Any variance from these methods must be approved by ETSU, in advance of any work, by means of the Variance Approval process. All proposals, offers of work, designs or scope must be reviewed with ETSU for final owner-acceptance before pricing or execution of work. This document does not specifically address legalities or safety protocol in any detail. All installers must comply with the work and safety policies at ETSU at their own risk.

### Installer Procedures

Installers must be certified by the manufacturer of the system(s) they are installing and be able to certify the installation for the manufacturer's full applicable warranty and period. Follow all manufacturers' instructions and install equipment in accordance with applicable codes and regulations, the original design and the referenced standards. In the event of any discrepancy, immediately notify ETSU or the Contractor as applicable through the proper channels. Do not proceed with installation. Protect all materials during transit, storage, and handling to prevent damage, theft, soiling, and misalignment. Do not store equipment where conditions fall outside manufacturer's recommendations for environmental conditions. Do not install damaged equipment; remove from site and replace damaged equipment with new equipment.

Hubbell Premise Wiring is the benchmark used for equal or equivalent on material, methods and warranties for copper solutions. Check with ITS on-warranty qualification requirements on optical fiber installations.

The installer is responsible for all coordination of work with ITS including but not limited to:

- Jobsite access and availability (including key policies and hours of work).
- Materials and other items. Note: The installer is responsible and liable for all tools, equipment, materials and all other items until completion of work or acceptance by ETSU.
- Vehicle parking rules and site laydown boundaries
- Application and use of all safety protocols and procedures
- All emergency and alternate plans in the event of an outage, cut, or damage to owner facilities or infrastructure. The installer will take no action that will interfere with, or interrupt, existing building services unless previous arrangements have been made with the University's representative(s). The work shall be arranged to minimize down time.
- Maintaining current information on emergency contacts, procedures, etc.
- If construction or installation drawings are provided by ETSU, the installer must utilize them in their original form – do not scale drawings.
- The installer is responsible for any damage, outages, delays, and corrections of such, created or caused by the installer.

### **Installers are required to have:**

- All necessary tools and calibrated test equipment for all work
- Trained and Certified technicians to operate all tools and equipment
- Current and valid certifications from applicable manufacturers, BICSI, and other entities as required per scope.
- Have the ability to test, record and produce drawings
- Provide material that is new and free of any defects, delivered to the job site in the original packing.
- An in-house RCDD assigned as a Project Manager

### **Expected Operational requirements for installers:**

- Professional in all interactions with Faculty, Staff and Students. This includes showing due care at all times, being mindful of your surroundings and use of language
- Professional In appearance. This includes all staff to be uniformed with company logo and carrying both a current and valid form of identification. No objectionable graphics or language on clothing is permitted.
- Follow Campus policies as in the no tobacco, no alcohol, and Parking Policies for all vendors including permits.
- Vehicles with business signage that clearly identify and associate them with the vendor, including phone contact info.
- All areas of work shall be cleaned daily including sweeping and vacuuming (as applicable) and shall be free of hazardous debris, items or materials.
- Follow all other campus policies as applicable.

**Inspections, Walkthrough's, and Commissioning:**

- The Installer is responsible for conducting, at minimum, a pre-installation site survey investigating and documenting all existing site and building conditions pertaining to communications. This must include but not be limited to items such as existing topography, soil conditions, conduit and pathway systems, cable, cable termination types/sizes, existing systems equipment locations, plenum and non-plenum requirements, special conditions, etc., which potentially impact the new installation or require relocation/demolition.
- All materials and workmanship work is subject to inspection and review at any time by qualified ETSU personnel. Contact ITS for required benchmark or scheduled inspections for each project.
- Final inspections must be done prior to turning in final documentation and test results. The preliminary documents will be made available for review during this walk-through inspection.
- Cables and other materials with visible defects including kinks, twists, crushed or depressed areas, cuts, painted or smashed will be replaced at the installers expense regardless of any passing test results. The installer shall take reasonable steps to protect their installation in a construction environment. Free of dirt, defects, and debris.

**Warranties and Registration of Work:**

ETSU requires all cabling installed at ETSU facilities to be installed per manufacturer instructions, including having accompanying documentation including as-built drawings indicating all outlet locations and labeling. All cabling infrastructure installed must be recorded and registered with the manufacturer's warranty program according to its terms and agreements. Copies of all records shall be given to ETSU upon completion of work, including a copy of the application for warranty registration.

1. Copper Cabling - ETSU ITS requires all copper installations to have a 25-year warranty. This warranty shall include all types of telecommunications services such as Power over Ethernet (PoE) Voice over IP (VoIP), LAN Security Cameras, Wireless LAN and any future services that meet ANSI/TIA/EIA and or IEEE specifications. ETSU ITS has benched marked Hubbell's MISSION CRITICAL® Warranty and System Performance Guarantee Program in determining equal or equivalent. Follow the instructions of Appendix D. For further information on the warranty program go to: <http://www.hubbell-premise.com/MissionCritical.asp>

2. Optical Fiber Cabling - ETSU ITS requires all fiber optic installations to have a 25-year warranty. Either with Corning, Hubbell, or other pre-approved manufacturer.

**Corning Fiber Optics Installers:**

Installer must have the Corning Optical Communications (NPI) Network of Preferred Installer Warranty. The installer must be in good standing with Corning Optical Communications warranty program and have the ability to offer a 25-year end-to-end warranty on the Corning optical fiber solution. The installer shall provide their current and valid Corning NPI certificate with the bid. No Corning Optical Communications Site-Specific warranties will be accepted. The bidding installer shall use all Corning Optical Communications manufactured optical fiber products.

**CommScope Fiber Optics Installers:**

The System Warranty applies only to Products that are installed by an Authorized Partner, at the location listed on the System Warranty Certificate. It's installed in compliance with CommScope's written design, engineering and installation procedures.

---

## SECTION 2 - CODES, STANDARDS AND AUTHORITIES HAVING JURISDICTION

---

Parties to installations based on this document must also apply the editions of the codes and standards indicated unless directed otherwise by the authority having jurisdiction (a Non-ETSU municipal government code enforcement official, THEC and/or The State Building Commission including the Office of the State Architect, SFMO or any appointees of such). NOTE: This is not the complete list of all applicable codes, standards, and policies that apply to design and construction at ETSU. Contact ETSU for a complete and updated list. Some applicable standards may be subject to scope and/or budget.

ETSU Policy 500.2 – Communications Design Standard (Latest Edition)

Building Industry Consulting Service International (BICSI)

- Information Technology Systems Installation Methods Manual – Latest Edition, and Outside Plant Design Reference Manual – Latest Edition

International Building Code (IBC 2012, except ch 11,34)

International Mechanical Code (IMC 2012) and ASHRAE 62.1-2013 and 90.1-2010

International Fire Code (IFC 2012), 510

Tennessee Department of Commerce and Insurance, State Fire Marshal's Office – Codes, History and Enforcement

Federal Communications Commission (FCC) Part 68, Connection of Terminal Equipment including Docket 88-57

National Fire Protection Association (NFPA)

- NFPA-70 (2017), National Electrical Code
- NFPA 101 (2012), Life Safety Code

ADA Standards for Accessible Design (2010, Titles II and III)

Telecommunications Industry Association (TIA) and related Standards

- TIA-5017, Telecommunications Physical Network Security Standard
- TIA-568.0-E, Generic Telecommunications Cabling for Customer Premise
- TIA-568.1-E, Commercial Building Telecommunications Infrastructure Standard
  - E-1, Addendum 1 - Balanced Single Twisted-pair Cabling; Cabling Requirements for Wireless Access Points Standard
- TIA-568.2-D, Balanced Twisted-Pair Telecommunication Cabling and Components Standard
  - D-1, Balun Requirements for Category 8 Testing
  - D-2, Addendum 2 – Power Delivery over Balanced Twisted-Pair Cabling
- TIA-568.3-E, Optical Fiber Cabling Components Standard
- TIA-568.4-E, Broadband Coaxial Cabling and Components Standard
- TIA-568.6, Single Pair Multi-Drop (SPMD) cabling and component specifications.
- TIA-569-E, Telecommunications Pathways and Spaces – including Addendum 1 (D-1)
- TIA-606-D, Administration Standard for Telecommunications Infrastructure
- TIA-607-D, Generic Telecommunications Bonding and Grounding for Customer Premises
- TIA 758-B, Customer Owned Outside Plant Telecommunications Cabling Standard
- TIA 862-B, Building Automation Systems Cabling Standard for Commercial Buildings
- TIA 1179-A, Healthcare Infrastructure Standard
- TSB-162-B, Telecommunications Cabling Standards for Wireless Access Points
- TIA TSB-5018, Structured Cabling Infrastructure Guidelines to Support Distributed Antenna Systems
- SCTE 77 Underground Enclosure Integrity
- AASHTO H-20 and HS-20 Designed Loads for Precast Assemblies
- EIA/ECA 310-E, Cabinets, Racks, Panels and associated Equipment

American National Standards Institute (ANSI) and IEEE collaborative standards

- ANSI/BICSI 006-2020, Distributed Antenna System (DAS) Design and Implementation Best Practices
- ANSI/TIA 4966 Telecommunications Infrastructure Standard for Educational Facilities
- ANSI/SCTE 77 Underground Enclosure Integrity
- ANSI/ESD S7.1-2005 Anti-Static Discharge Flooring
- ANSI/ESD S6.1-2009 Anti-Static Discharge Grounding
- IEEE 802.3.xx, Physical and Data Link layer standards for LAN's, includes Ethernet, Fast Ethernet, Gigabit and 10 Gigabit Ethernet 802.3af PoE & 802.3at PoE+, 802.11ax Wi-Fi 6 and 6E
- IEEE 802.11. xx, Wireless LANs as applies per ETSU-ITS

\*All applicable State, Municipal & Campus codes, standards, policies and statutes including State Building Commission and THEC

---

## SECTION 3 - TELECOMMUNICATION ROOMS AND SPACES

---

**3.0 Overview:** All telecommunication rooms and spaces including but not limited to TR/ER/CP/MDF/IDF and all OSP spaces and boxes shall be compliant with BICSI's TDMM and ITSIMM (current editions). This shall include pathway and space sizing and types.

**3.1 Additional:** ETSU's communications space and pathway requirements and specifications are included in the ETSU Facilities Communications Design Standard (CDS) Policy 500.2. Please refer to it for more details regarding minimum standards and design requirements.

**3.2 Prohibited:** The following items, materials, systems and equipment are prohibited from being installed in communication rooms of all types without a written approved variance by ETSU-ITS:

- a. Fire alarm panels or FACP controls of any kind
- b. Mechanized or Electric door and building opening controllers (CBORD, etc.)
- c. Monitoring equipment or telemetry (BAS/weather/etc.)
- d. Any equipment not supported by ETSU-ITS

**3.3 General:** The following items, materials, systems are typical for all communication rooms at ETSU. The installer must coordinate any work or prior to execution with ETSU-ITS for written approval. Any work done without acceptable design or authorization is subject to demolition/removal and associated penalties at the expense of the installer or contractor.

**a. Equipment racks and related components:** A minimum of (2), two-post racks with vertical and horizontal wire management is required per ER/TR. One rack (known as the equipment rack) is for the optical fiber backbone cabling and bulkheads as well as ETSU-ITS active switchgear. The other rack (known as the cabling rack) is for all passive twisted-pair cabling media serviced from that space. A minimum 3-foot clearance of working space should be maintained from the front and rear edges of active equipment, measured from the deepest edge of equipment. See details 5 and 8 of the Facilities communications Design Standard Policy 500.2. Install ITS-specified patch panels in the cabling rack. There shall be horizontal wire management for patch panels, one installed above and the other underneath each patch panel. A minimum of 18" wide ladder-rack style cable tray shall be installed around room and toeach rack. Racks and cabinets must meet EIA/ECA-310-E standard. Provide and install A/V cabinets as specified by ITS special projects group if required. Provide and install rear cable management bar for strain relief at each patch panel. Cables shall be dressed and terminated evenly 50/50 split leftand right in groups of 24 or less. Racks, enclosures, patch panels, etc., shall be labeled top and bottom, front and back.

**b. Telecommunications Enclosures:** A TE should serve an area not greater than 3,600ft<sup>2</sup> and only to be used if a TR is not available or impractical. ETSU ITS will determine the size and if a TE is to be used. The TE is not to be installed in furniture systems. The TE should be accessible and controlled against unauthorized access.

If active equipment is to be housed in the TE:

- A minimum of one dedicated 120V, 20A, non-switched, quad electrical outlet receptacle should be provided.
- Sufficient number of air changes. Refer to equipment manufacturer for Standards.
- Must be bonded and grounded per ANSI J-STD-607-A.
- Doors hinged or removable to open at least 90°.
- Light adequate for work and service as determined by ETSU-ITS
- TE's must not be used in lieu of a TR on a given floor.

**c. Plywood on walls:** At least two adjoining walls of each TR must have 3/4" thick AC Grade plywood installed on them. All plywood must be painted with two coats of fire-retardant paint or additive to specifications (see ETSU-ITS) and must be 4'x8' sheets mounted vertically with the bottom of the plywood mounted 6" from finished floor with the best side toward the room. Plywood shall be completely painted prior to the installation of any equipment. Plywood must be permanently fastened to the wall by means of wall anchors, using galvanized, zinc plated, or stainless-steel hardware with a flat head. Finished installation shall have flush appearance with countersunk screwheads to prevent splitting. Drywall screws are not acceptable.

**d. Cable pathways entering the ER/TR:** The number and type of telecommunications circuits that will be brought into the building must determine the number and size of inter-building conduits entering this room. The minimum number and size of conduits to a building from outside is three (3) 4" conduits, with two of the conduits having two (2) detectable MaxCell Edge innerducts each with their own color I.D. All innerducts must be installed by means of manufacturer-approved swivels as directed. All additional service entrance conduits must terminate in the service entrance room or as directed by ETSU or the SP. All conduits entering from the floor must extend to a minimum of 4" AFF UNO. Consult ETSU for the size, quantity and locations of all other pathways and sleeves in the ER/TR.

**e. Access and Security:** ETSU-ITS calls for the physical protection of all components inside each telecommunications room. Contact ITS directly for their current policy on locking hardware/access policy.

**f. Turnover (construction):** Before any terminations and installation of equipment, the communication rooms and spaces must be in a finished state. Free of dust and debris with all walls and ceiling painted to finish coat and floors installed or treated.



---

## SECTION 4 - OUTSIDE PLANT (OSP): CONDUIT, PATHWAYS, SPACES AND CABLING

---

**4.0 General:** All cabling installed must comply with current edition BICSI ITSIMM, Chapter 5 “Cable Installation.” Before designing any OSP, the designer and or consultants will need to meet with ETSU ITS for system requirements and methods. All OSP at ETSU is underground and in conduit. No aerial and no direct bury installation of cabling is permitted. The contractor shall be familiar with all conditions, duties and liabilities as respects to utility and underground locating prior to any work and all associated permissions for work and consulting with all parties of vested interest throughout the design and construction process. Complete and thorough locating should be accomplished prior to any work. (Tennessee One Call / 811).

J-hook type supports for any cabling must be installed on maximum 5’ centers, in regular intervals, allowing for no more than 12” of cable sag. A minimum clearance of 8” must be maintained wherever possible above j-hooks and cable tray. Cables must be bundled in TR’s per BICSI N1 and N2-17. J-hooks and supports must comply with the uses and material types as directed in the ETSU-ITS guidelines. This includes cable quantities where applicable. All cabling supports and pathways must be independently supported and secured from movement per NEC 300.11. Note: See ETSU-ITS installation standards for maximum allowable fill for all J-hook and cable types. Consult ETSU for more details. J-hook types and installation methods should not interfere with cabling ability to achieve passing test results. The installer is responsible for installation methods and modalities.

All non-fiber cabling shall have conductors of solid copper. No copper annealed or copper-clad cabling shall be permitted under any circumstances, including request by variance. (See NEC 800.179 and TIA 568.2-D section 5-3).

Consult ITS on the provision and/or installation of any type of patch cords as installations vary.

Paint or other coatings applied to any type cabling jackets (intentional or unintentional) is not permitted. This is considered an alteration to intended use and purpose and will void any acceptance by ETSU or warranty by manufacturer(s). Any installed cabling that gets painted or coated over shall be replaced before it is accepted by ETSU. See NFPA-70 2020 sections 725.24, 760.24, as well as others.

**4.1 Backfill, Encasement and Separation:** Prior to backfill and concealment, all OSP installations must be observed and approved by ETSU. The designers must add this note to all site and OSP drawings and include it in any pre-construction directives. Consider concrete encasement of conduit when minimum depth cannot be attained, conduits pass under roads, sidewalks, driveways, or when bend point may be subject to shifting or movement. Also special or sensitive circuits (Public Safety, Life Safety) may have particular encasement needs. Consult with ETSU prior to design. When communications conduit and cabling require separation from other utilizes, maintain a minimum of; 1) 12” of well tamped earth from power, 2) 3” from electrical power when encased in concrete and 3) 2’-0” from steam lines.

**4.2 Identification:** Provide identifying metalized (detectable and conductive) minimum 6” wide warning tape above all OSP conduit. Warning tape must be placed 12” maximum below finished soil grade and run continuous and center above conduit sections. All conduits must be labeled inside maintenance holes, hand holes and Telecommunications Rooms.

**4.3 Paving, Surfacing and non-Paved Restoration:** Follow guidelines set by contract documents and consult ETSU Facilities. All OSP pull boxes must be flush with grade on all sides to allow for mowing, etc.

**4.4 Conduit:** Communications conduit and fittings must be made of polyvinylchloride, PVC schedule 40 pipe for most applications. Schedule 80 must be utilized for passing under parking lots or drive areas, streets, and other load bearing applications. Solvent weld fittings are to be used and joints must be watertight. All conduits must be provided with a sequentially marked pulling tape in English or metric markings with a minimum of 1200 lbs. pulling tension. Conduit must be thoroughly cleaned after placement. During construction and after the conduit is completed, the ends of the conduits must be sealed as specified in this document. No conduit section must exceed 100’ in distance without a handhole or pullbox. The pull box must be in a fully accessible area away from vehicle and designed pedestrian traffic. Each conduit section including those containing innerduct must have a minimum 3/8” nylon pull rope (mule tape) rated at a minimum 200lb. tensile strength.

**4.5 Conduit Formation:** Where practical, conduit formations using single-bore conduit should be arranged so that orderly cable racking can be accomplished within the maintenance hole or handhold and that minimum changes are made in the formation as it enters the maintenance hole. Main conduit formations must enter the end walls of a maintenance hole as shown on Detail 4 of the ETSU CDS policy. In OSP applications there must be a minimum of three (3) 4" conduits from pullbox to pullbox. Conduits must enter and exit pullboxes in a straight (aligned) formation, entering and exiting at opposite sides of the box. Conduits entering buildings must be sloped down and away from buildings to create a substantial drain slope. Conduits, regardless of whether they are empty or contain cabling, must be free of debris and water at all times and must be sealed with approved pliable seal at all openings.

**4.6 Bends:** The contractor must use the longest radius bends possible. All bends must be long, sweeping bends with a radius not less than 10 times the internal diameter of conduits. NOTE: 90-degree bends are not approved in any circumstance. Factory manufactured bends are to be utilized (non-heated). No more than two bends are permitted in a length of conduit without a pullbox. Pull boxes must not be utilized in lieu of a conduit bend.

**4.7 Terminating Conduit:** (Reaming). All ends of conduit must be reamed and all protruding ends should be fitted with bushings at ends.

**4.8 Depth:** The top of all OSP communications conduit must be buried at least 2'-0" below the surface of the ground. See 'Detail 3' of the ETSU CDS policy.

**4.9 Innerduct:** All OSP conduit shall contain innerduct. All innerduct placed inside OSP conduit must be MaxCell Edge color-coded detectable 3-cell innerduct. When initial cabling is installed in an empty innerduct, the middle (center) cell must be occupied first. All OSP conduit (including those encasing innerduct) must have a pull rope installed as well. (See part 3.4 of this section). Each innerduct is to have different color ID markings and must be installed per the manufacturer's instructions including the use of manufacturer approved swivels. No kinked or twisted innerduct will be accepted. Pull tapes must remain free floating throughout the installation. Consult ETSU-ITS on the requirement for inside plant innerduct (MaxCell Premise) for interior riser pathways.

**4.10 Handholes/Pullboxes:** HH/PB's are to be open bottom with a minimum dimension of 30"x48" with cover permanently labeled "COMMUNICATIONS" by the manufacturer. All covers must have a pull slot with center pin for opening and setting. No conduit section between HH/PB's must exceed 100'. When the designer is considering tying a new conduit into an existing HH/PB, the designer must consult with ETSU first to see if the existing HH/PB should be replaced with a larger one. When conduits enter a HH/PB they should be designed to do so no lower than 2'-0" below finished grade. Conduits must enter and exit HH/PB's in a straight (aligned) formation. All covers must be flush with grade to allow for grounds equipment, mowing, mobility, etc. New HH/PB locations must be in a fully accessible area away from vehicle and designed pedestrian traffic (streets, sidewalks, etc.). Existing HH/PB locations that are to remain unaltered but because of new construction it has been determined will be exposed to occasional lightweight vehicular and pedestrian traffic, must be converted to rated HH/PB's that exceed a maximum rating for expected traffic for that location per ANSI/SCTE 77 standards and tiers. For HH/PB locations designed to be in deliberate traffic including heavy vehicles (earth moving, construction, emergency and first responder vehicles) they must meet, at a minimum, AASHTO H20 standards for all materials. All cabling and conduit openings must be clearly and permanently labeled at each HH/PB. When cabling is to be installed at each HH/PB, a minimum 25' service loop in each cable must be installed and appropriately secured to the side of the HH/PB.

NOTE: Prior to backfill and concealment, all OSP installations must be observed and approved by ETSU. The designers must add this note to all site and OSP drawings and include it in any pre-construction directives.

#### **Additional information on Outside Plant conduit, cabling, conduit bodies and boxes**

Where OSP conduit and cabling transitions into existing building walls/facades/architectural members, the use of Conduit Bodies must be designed and utilized. These bodies have removable or hinged weatherproof covers to allow access to the cable for pulling purposes only. It is used to give access to cabling or allow change in direction of the conduit pathway system. Note that it is critical to meet the minimum bend radius requirements for cabling. These type conduit bodies (a/k/a "Smart" conduit bodies such as from Madison Electric Products) have built-in internal radius members that ensure that the cabling placed inside meets the industry-standard bend radius. Only these type conduit bodies are to be used in the design and construction of these type pathways. NOTE: See Detail 13 in the Appendices section of the ETSU CDS for more detail.

For system conduits, pull boxes, routing, termination, risers, horizontal runs, sizing, etc., follow industry standard requirements. Raceway definitions must comply with NEC definitions. There must be a maximum conduit fill ratio of 40 percent to be accommodated for when sizing conduit.

Conduit runs must be equipped with a pullbox (inside), or maintenance hole (outside), after two 90-degree bends or an accumulation of 120degrees of total pathway deviations from a straight line between each point of access. For conduit diameters 53 mm [2 in.] or less, minimum bend radius must be six times the internal diameter of conduit. For conduit diameters exceeding 53 mm [2 in.], conduit bend radius must be 10 times internal diameter of conduit. For conduit enclosing optical fiber cabling minimum conduit bend radius must be 10 times internal diameter of conduit.

All designs should provide and allow for a separate cable distribution system including dedicated continuous conduits for critical, life, emergency, safety and protection systems (i.e. emergency phones, emergency voice communications from elevator cars, parking lots, stairwells, FACP's, etc.

NOTE: No conduit bodies, enclosures, cabinets, pull boxes or other transitional spaces used or designed for access to pull cabling thru shall be used to house any active equipment, primary grounding, surge protection or other components not directly related to the support and routing of the cabling itself. Any other terminations, surge protection, active components, power receptacles, means of grounding etc. must utilize separate and appropriately sized enclosures or conduit bodies for this purpose. These will be permitted to have connections thru approved conduits between enclosures and housings for means of connection. Contact ETSU for more information and refer to Detail 10 in the Appendices section of the ETSU CDS. No exposed Class 2 cabling (LV/comm/etc.) of any kind is permitted at ETSU. No aerial or direct buried communications cabling of any kind is permitted at ETSU. All OSP cabling infrastructure must be installed in conduit pathways by approved means.

---

## SECTION 5 - INSIDE PLANT (ISP): CABLE TRAY, CONDUIT, SUPPORTS AND CABLING

---

All cabling installed must comply with current edition BICSI ITSIMM, Chapter 5 "Cable Installation." Open-top cable supports (J-hooks specifically) are approved for use where needed as horizontal free-wire pathways to provide support for cabling from outlets to the cable tray in accessible areas. J-hooks for horizontal cabling must be installed on maximum 5' centers, in regular intervals, allowing for no more than 12" of cable sag. A minimum clearance of 8" must be maintained wherever possible above j-hooks and cable tray. Cables must be bundled in TR's per BICSI N1 and N2-17, including 20 more than 24 cables per bundle. J-hooks and supports must comply with the uses and material types as directed in the ETSU-ITS guidelines. This includes cable quantities where applicable. All cabling supports and pathways must be independently supported and secured from movement per NEC 300.11. Note: See ETSU-ITS installation standards for maximum allowable fill for all J-hook and cable types. Consult ETSU for more details. J-hook types and installation methods should not interfere with cabling ability to achieve passing test results. The installer is responsible for installation methods and modalities.

All non-fiber cabling shall have conductors of solid copper. No copper annealed or copper-clad cabling shall be permitted under any circumstances, including request by variance. (See NEC 800.179 and TIA 568.2-D section 5-3).

Consult ITS on the provision and/or installation of any type of patch cords as installations vary.

Paint or other coatings applied to any type cabling jackets (intentional or unintentional) is not permitted. This is considered an alteration to intended use and purpose and will void any acceptance by ETSU or warranty by manufacturer(s). Any installed cabling that gets painted or coated over shall be replaced before it is accepted by ETSU. See NFPA-70 2020 sections 725.24, 760.24, as well as others.

### Cable Tray (all areas except within telecommunication rooms)

Wire basket type tray for backbone and horizontal cabling shall be sized appropriately (allow 25% growth) and have a 2" minimum depth. Tray's shall be located a minimum of 3" above ceiling tile and have a minimum of 12" of unobstructed access above tray. When designing the layout of the tray, the designer should ensure that other building components (e.g., lighting fixtures, structural supports, air ducts) do not restrict access to the tray. Wire basket must be cut using cutting tool for wire basket and not typical bolt cutters. All cable tray should be installed with either a two-level system for separation of AV and general ITS 'data' cabling, or a single layer cable tray with a metallic center divider.

### Consolidation Points

Consolidation points should have appropriate security, such as key locking, tool removable covers, or other means of security. Furniture or spaces used to house consolidation points must have sufficient space to allow for anticipated horizontal cable slack storage, strain relief and terminations. Suspended ceiling spaces and floors may be used, provided the space is accessible without moving building fixtures, equipment, heavy furniture or disturbing building occupants. Consolidation points in plenum-rated spaces must conform to applicable codes.

### Ceilings

All ceiling removal and restoration required for the execution of this work shall be the responsibility of the contractor. All cabling installed exposed in accessible ceiling systems shall be supported by cable tray or J-hooks. All J-hooks shall be supported directly from the structure above or wall mounted, as applicable, independent of ceiling framing, electrical conduit, mechanical piping and ductwork. No vinyl cable ties or bundling allowed. Communication cable and infrastructure shall be independently supported. Do not support or tie-wrap any cables to ductwork, plumbing lines, fire suppression, electrical conduits, mechanical systems, or ceiling system.

Any equipment, active or inactive, mounted to and directly supported by a ceiling tile, grid, or existing grid hanging wire already supporting an object is not permitted. All cabling and equipment shall be independently and properly supported and not laying on or relying on ceiling tiles for support. See NEC and BICSI for more information.

## ISP/OSP general conduit notes

All designs should provide and allow for a separate cable distribution system including dedicated continuous conduits for critical, life, emergency, safety and protection systems (i.e. emergency phones; emergency voice communications from elevator cars, parking lots, stairwells, FACP's, etc.

### Horizontal Conduits

- All horizontal conduits for ETSU communications outlets (voice/data/video/Wi-Fi/cameras/displays/floor boxes and poke-through assemblies/standard A-V outlets, etc.) must be 1" diameter EMT. See detail 2 of the ETSU CDS for related specifics and conduit rough-in requirements including box sizes and methods of construction. No more than six, four-pair cables may be in a single one-inch conduit.
- Conduit entries at pull boxes must be arranged so that cables passing through the box enter and exit at opposite sides of the box. ETSU requires conduit elbows (sweeps) that maintain cable bend radii for changes of direction.
- Surface metal raceways are not acceptable and must not be approved for wire or cable on the outside walls. In interstitial spaces and above solid ceilings (inaccessible areas), route conduit serving work area outlets and other type outlets to the nearest cable tray, cabinet, or rack as applicable.
- Conduit from work area outlet to above accessible ceiling interior diameter must be a minimum of one inch and be terminated to a 3-inch deep, 4-inch square box.
- No section of conduit must be longer than 30m (100 feet) between pull points.
- No section of conduit must contain more than two 90-degree bends, or equivalent, between pull points (e.g., outlet boxes, pull boxes, distributor rooms). If there is a reverse (U shaped) bend in the section, a pull box must be installed. For conduits with an internal diameter of 2 inches or less, the inside radius of a bend in conduit must be at least 6 times the internal diameter. For conduits with an internal diameter of more than 2 inches, the inside radius of a bend in conduit must be at least 10 times the internal diameter. Bends must not contain any kinks or other discontinuities that may have a detrimental effect of the cable sheath during cable pulling.
- Conduit fittings must not be used in place of pull boxes.
- The communication cabling contractor shall provide plastic and/or grounding bushings, as applicable, on all conduit sleeves, stubs and conduit terminations

### Pull Boxes for Horizontal Cabling

- Pull boxes should be readily accessible and not placed in a fixed false ceiling space unless immediately above a suitably marked access panel.
- A pull box must be placed in a conduit run where: a. The length is over 100 feet, b. there are more than two 90-degree bends or equivalent, or c. There is a reverse (U-shaped) bend in the run.
- Pull boxes must be placed in a straight section of conduit and not used in lieu of a bend. The corresponding conduit ends should be aligned with each other.
- Where a pull box is required with conduits smaller than 1 ¼", an outlet box may be used as a pull box. Where a pull box is used with conduits, it must be sized, at minimum, per table 7 of ANSI/TIA-569-E section 9.9. Consult ETSU prior to sizing.

**Table 7 – Pull box sizing**

<b>Metric designator (trade size)</b>	<b>Width mm (in)</b>	<b>Length mm (in)</b>	<b>Depth mm (in)</b>	<b>Width increase for additional conduit mm (in)</b>
27 (1)	102 (4)	406 (16)	76 (3)	51 (2)
35 (1-¼)	152 (6)	508 (20)	76 (3)	76 (3)
41 (1-½)	203 (8)	686 (27)	102 (4)	102 (4)
53 (2)	203 (8)	914 (36)	102 (4)	127 (5)
63 (2-½)	254 (10)	1067 (42)	127 (5)	152 (6)
78 (3)	305 (12)	1219 (48)	127 (5)	152 (6)
91 (3-½)	305 (12)	1372 (54)	152 (6)	152 (6)
103 (4)	381 (15)	1524 (60)	203 (8)	203 (8)

## Horizontal Cabling (all types)

### **5.0 General:**

All cabling installed must comply with current edition BICSI ITSIMM, Chapter 5 "Cable Installation." All abandoned cabling as defined by the NEC shall be removed in its entirety when it is found inside areas of installation or limits of work – or – labeled for future use, as deemed by ETSU-ITS. Horizontal cabling is the portion of the ICT cabling system that extends from the work area telecommunications outlet/connector to the HC (FD) in the TR. The term horizontal cabling is used because this part of the cabling system typically runs horizontally along the floor and ceiling of a building.

Horizontal cabling systems consist of two basic elements:

- Horizontal cable and associated connecting hardware transport signals between the telecommunications outlet/connector and the HC (FD). This cabling and associated connecting hardware are referred to as a permanent link.
- Pathways used to distribute and support horizontal cable and connecting hardware between the telecommunications outlet/connector and the HC (FD) located in the TR.

In general, installations to work areas and supporting equipment (standard WAO's) require a minimum of two separate Category 6 cables unless otherwise directed by ETSU. The installer must meet with ETSU-ITS to determine applications, methods and materials prior to all installations. No surface mount raceway (Panduit, Wiremold, etc.) is allowed without prior approval from ETSU administration.

- All cables shall be installed as single continuous "home-run" pulls from connector block to connector block, or from patch panel in the telecommunications room to the data workstation outlet in the work area.
- The maximum allowable horizontal cable distance (permanent link) from the patch panel/rack in the TR to the work area outlet for all devices utilizing BTP cabling is 295' (90 meters). This distance includes the mandatory minimum slack for the outlet box, service loops, etc. The permanent link as defined by the TIA is the ETSU standard for all horizontal cabling segments.
- The minimum amount of cable slack in the TR, shall be 3m (10'). Above WAO rough-ins the cable slack shall be 1m (3.28'), and at the WAO for termination cable slack shall be a minimum of 8". Cable slack should not be stored in bundled loops. Cable loops have a degrading effect on cabling performance. Cable slack should be stored in an extended loop or in a figure-eight configuration.
- All UTP/BTP cable terminations shall be done to TIA-568.2-D Section 5.7.5 as T-568A scheme for pin/pair assignments.
- Conduits and pull box lids must be marked as "COMMUNICATIONS".
- Splices in any horizontal cabling are not permitted.
- Flexible metallic conduit (metal-flex) or plastic tubing is not allowed. Short lengths of smooth flexible Non-Metallic Conduit is allowed when the size is increased 1 trade size, with prior ITS approval.
- No vinyl cable ties are permitted inside communication rooms. Contractor shall provide and install approved Velcro strips for securing cables.
- Terminate all conductors; no cable shall contain unterminated elements. Make terminations only at indicated outlets, terminals, cross-connects, and patch panels.
- Bundle, lace, and train conductors to terminal points without exceeding manufacturer's limitation on bending radii, but no less than radii specified in BICSI ITSIMM.
- Use lacing bars and distribution spools. Installer shall not lace or secure cabling bundles to horizontal cable tray cross members inside the TR unless maintaining cabling separation cannot be accomplished otherwise. Consult ETSU for more information. Bundles shall be limited to 24 cables or less.
- Do not untwist UTP cables more than 1/2 inch from the point of termination to maintain cable geometry.
- Do not exceed a pulling tension of 25 lb. during the installation of 4-pair balanced twisted-pair cables. Refer to manufacturer's pulling tension guidelines for multi-pair cables.
- Cable bend radius may vary depending on the cable condition during installation and after installation when the cable is at rest (no-load). The minimum inside bend radius, under no-load or load, for 4-pair balanced twisted-pair cable shall be four-times the cable diameter. The minimum bend radius for multi-pair cable shall follow the manufacturer's guidelines.
- Route all cables and cable raceways parallel to or perpendicular to building structure.

**5.1 Work Area Outlets (WAO):** Angled 4 port, faceplates are the standard faceplate used in Administration, Classroom, Mechanical and Building Automation spaces. 1 or 2 port flat faceplates are used in student rooms. Angled faceplates are only to be used in the vertical position. The use of other type and/or color of materials shall have prior approval from ITS. ETSU has standardized on the colors of new data jacks. CAT6 jacks shall be orange and installed on blue-jacketed CAT6 cable and CAT6A jacks shall be green and installed on yellow-jacketed CAT6A cable. Special circuits and AV are to be yellow. On new installations, all drops are to be considered data unless noted otherwise. All work area outlet boxes (rough-ins) shall be 4”X4”X3” deep.

**5.2 Patch Cords:** Equipment and patch cords are smaller lengths of cables with connectors at both ends that allow the connecting of equipment to an outlet or the interconnection of equipment and patch panels. All patch cords shall be factory made, booted, and certified. Balanced twisted-pair equipment and patch cords:

- May have stranded conductors for added flexibility.
- That use a stranded conductor have 20 percent more attenuation for 24 AWG [0.51 mm (0.020 in)] and 50 percent more attenuation for 26 AWG [0.41 mm (0.016 in)] as compared to a solid conductor of the same gauge. – New standards permit the use of 28 AWG [0.32 mm (0.013 in)] patch cords with an attenuation factor of 1.95 (increased attenuation reduces the total channel length).
- Shall meet or exceed the same performance rating as the horizontal cabling in use (except for insertion loss).
- Usually have 8P8C modular plugs on the ends and must be factory molded. No handmade patch cords are permitted. All modular connectors on patch cords must be appropriate for conductor type (i.e. IDC solid crimp for solid conductor and IDC stranded crimp for stranded conductor).
- Must be balanced twisted-pair construction.

Check with ITS on whether patch cords are to be provided and/or installed in a project.

**5.3 Modular Plug Terminated Link (MPTL):** The MPTL, formerly known as a direct-attached connection, replaces the jack at the work area end of the horizontal cable with a field terminated plug. The work area equipment cord is no longer required. This is done to accommodate devices that seldom get unplugged such as security cameras, WAPs, and other networked devices of BAS, thereby eliminating the need for a work area outlet that would typically be installed in a ceiling. Although field terminated plugs are not recommended, MPTL plugs have been developed that ensure easier and more reliable field terminations. Because some of these plugs are physically larger than the typical equipment/patch cord plugs, the installer must check that there is enough space at the equipment port to accommodate the larger plug. This is critical on WAPs with two closely spaced ports. Also ensure that the performance category of the plug matches the performance category of the horizontal cable. An MPTL cannot be longer than 90 m (295 ft) but the link can have a consolidation point. See Chapter 6, Section 1 of the BICSI ISTIMM, for the proper adapters required for the link certification test. Consult ITS prior to any desired MPTL installations or applications.

**5.4 Power Poles / Utility columns:**

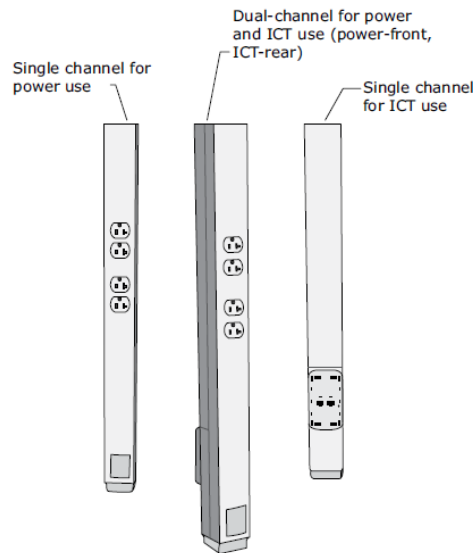

Figure 5.6 – Example utility columns for use with modular furniture (credit BICSI)

## Backbone Cabling (all types)

### 5.5 General:

All abandoned cabling as defined by the NEC shall be removed in its entirety when it is found inside areas of installation or limits of work – or – labeled for future use, as deemed by ETSU-ITS. The term backbone is given to the cabling and related components that are used between the spaces within an ICT system’s cabling structure, such as TRs, ERs, and TEs, that handle the majority of network traffic.

Backbone cabling consists of the backbone cables, IC (BD), MC (CD), mechanical terminations, and patch cords or jumpers used for backbone-to-backbone cross-connection. Backbone cabling includes cabling between buildings.

NOTE: The term mechanical termination refers to all optical fiber and copper terminations.

There are two types of backbone cabling:

- Interbuilding backbone cabling distributes telecommunications services between buildings and is referred to as cabling subsystem 2 or cabling subsystem 3.
- Intrabuilding backbone cabling distributes telecommunications services between telecommunications spaces (e.g., ER, TR) within a single building and is referred to as campus cabling.

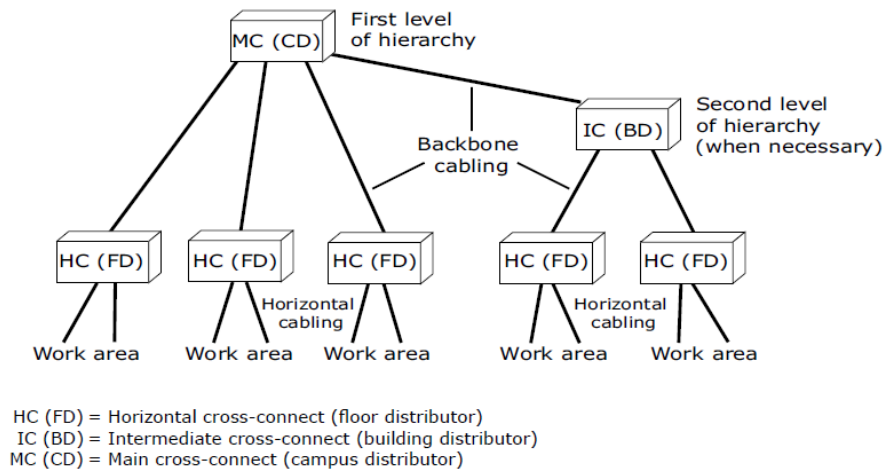

Figure 5.5 – Example of structured backbone cabling (credit BICSI)

The fiber optic riser backbone cable connecting 2 TR’s shall be a *minimum* of 12-strand single mode (OS2) and 12-strand 50 micron multi-mode fiber optic cables (OM3). Consult ITS prior to installation or precise strand count. Multiple TR’s shall have backbone riser cables installed in a ‘star’ topology, homerun from the main communications room as designated by ITS. Plastic inner duct is not permitted. Fibers are to be either in conduit or use Corning, Hubbell or CommScope armored cables as approved.



---

## SECTION 6 – SPECIALTY SYSTEMS AND PROCEDURES

---

**6.1 Multimedia Classrooms and Labs:** Consult ETSU ITS' Special Project Manager for installation requirements in classrooms and computer labs. All classrooms must be compliant with High-bandwidth Digital Content Protection (HDCP) using High-Definition Multi Interface (HDMI). Classroom sources and control will be provided using a Touch Panel Interface.

Multi Media design, installation, cabling, materials and methods, shall be done to the standards of AVIXA Standards, and Accredited Standards Developer (ASD). ITS gives preference to installers that have the AVIXA CTS-D and CTS-I certifications. Multimedia requirements include but are not limited to:

- Lectern with dedicated power
- Web Conferencing with instructor Voice Lift and Lecture Capture Capabilities
- Four networking cables connected to ETSU network
- Projectors or large displays with dedicated power
- Zoned or programmable controlled LED lighting
- Audio/Visual Control System
- Overhead power/speakers/projectors/microphones, all independently supported per NEC
- A multimedia chase, floor box, or floor poke-thru at lectern for all wiring. Coordinate any floor connections for power and data with ITS prior to specification and installation.

**6.2 Conference Rooms:** Consult ETSU ITS prior to conference room installations, as cabling and components can vary greatly. In general:

Each conference room shall have a minimum of two WAO's behind each display consisting of two data cables and quad electrical receptacle. Floor connections to displays require either a floor-box or floor poke-thru assembly as applicable, both must ensure pathways are installed for cabling from displays to floor-box or poke-thru (from above ceiling to below floor). See other documents for more details. See also Section 6.6 of this documents for more on displays.

**6.3 Emergency phones:** An Emergency Phone's type and location will need to be coordinated with several departments at ETSU. EP's must be installed as per the manufacture's specifications, including grounding and bonding and air gap spacing at the location per the NEC, along with any cable shielding or surge protection. Any operational interfaces for users must be installed at dimensions compliant with ADA.

**6.4 Elevator phones:** Elevator phone cable shall be CAT6 and be protected in minimum 3/4" diameter EMT conduit from elevator control panel to the TR. No more than two 90° bends between pull boxes. Terminate inside control room inside a minimum 4 X 4 X 3" deep electrical box outside of the equipment panel with a single port surface box (Intermediate Demarcation Point). Installation, testing and labeling shall be consistent with material and methods found in this standard. Box lid or cover shall be labeled "Elevator Phone".

**6.5 'Area of Rescue' phones:** Area of Refuge phone cabling shall be CAT6 and be protected in minimum 3/4" diameter EMT conduit from phone to TR. No more than two 90° bends between pull boxes. Terminate cable inside 4 X 4 X 3" deep electrical box with a 1 port surface mount outlet box (Intermediate Demarcation Point). Installation, testing and labeling shall be consistent with material and methods found in this standard. Box lid or cover shall be labeled as directed.

**6.6 TV's/Displays:** All displays of any type or use (TV's/displays/Digital Signage) shall require a data outlet consisting a minimum of 2 CAT6 cables, immediately adjacent to a quad electrical outlet as well as a rough-in for future cabling types. Outlets shall be located at a height so it will be behind the flat screen monitor/TV. See details below for "Type I" and "Type II" display details. Consult ITS's Special Projects manager for more information as installations vary. All installations that support displays must be property and adequately constructed. See elevation types in this section and general construction documents for more details.

NOTE: CONTACT TIM FERGUSON AT ETSU-ITS 791-4328 PRIOR TO ROUGH-IN ON THIS WALL

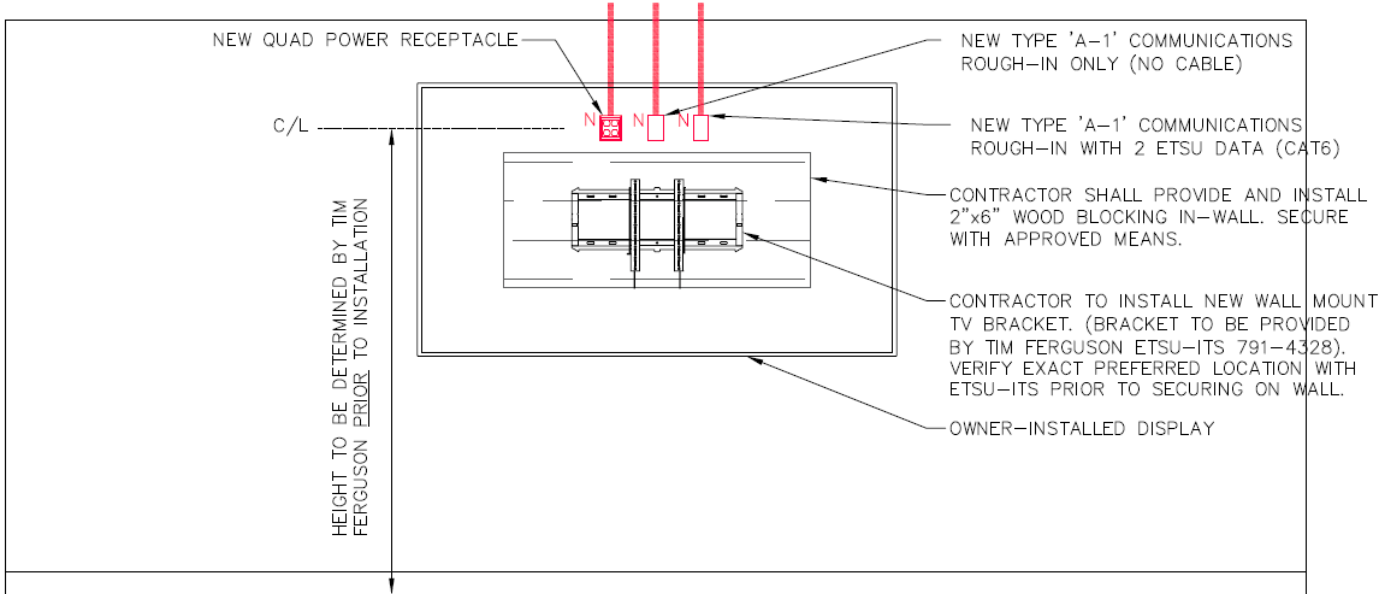

**DISPLAY TYPE I – TYPICAL ELEVATION**

NOTE: CONTACT TIM FERGUSON AT ETSU-ITS 791-4328 PRIOR TO ROUGH-IN ON THIS WALL

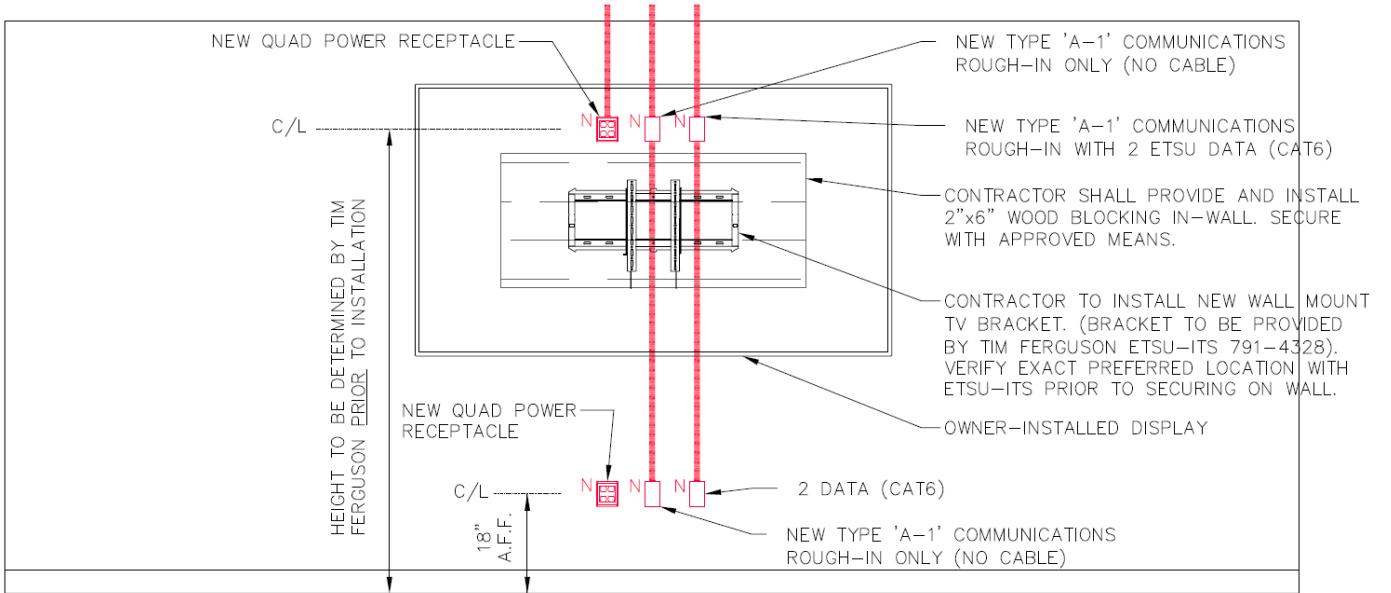

**DISPLAY TYPE II – TYPICAL ELEVATION**

**6.7 Fire Alarm Connections:** Cabling connecting the Fire Alarm System to the ETSU fiber optic network must follow the cabling standards in this document under the close direction of ETSU Environmental Health and Safety. Fiber optic cabling shall terminate in a wall mounted patch panel using a red patch cable to connect to the ETSU fiber patch panel (demarcation point). It is up to the contractor and EH&S to determine what connector is required for this patch. Fire Alarms that use phone lines for telecommunications must follow codes and methods of the Authority Having Jurisdiction and installed per BICSI, NFPA and ANSI/TIA applicable standards. All Fire Alarm cabling must be physically protected. Coordinate Fire Marshall Inspections with ETSU-EH&S and ETSU-ITS.

**6.8 Wireless Access Points (WAP / Wi-Fi):** ITS is responsible for the implementation, design, maintenance and troubleshooting of all issues related to the ETSU Wi-Fi network. A wireless site survey must be completed for all new construction and renovation projects to ensure that wireless access points are located appropriately for optimal performance and coverage. In Capital Projects this survey should be done after 100% Design and Development and before 50% Construction Documents.

#### Cabling for Wireless AP's

Horizontal cables shall not directly terminate to equipment except through a pre-approved MPTL connector. At minimum, ETSU standardizes on Wi-Fi 6 or 6E for all AP's (IEEE 802.11ax). A minimum of two Category 6A cables shall be homerun to serve each AP. Consult ETSU-ITS on types and quantities prior to installation. All AP cabling shall be CAT6A yellow-jacketed. All jacks for AP's shall be CAT6A green. All cabling for AP's shall be installed per TIA-568.1-E Addendum 1. Where ITS does not define AP locations or existing construction prohibits certain methods, all cabling shall comply at minimum to TIA-TSB-162-B (60'x60' zones, 80m maximum length).

#### Suspended / Acoustical Lay-In Ceiling Tile (ACT)

Access points located in areas with a suspended or lay-in ceiling tile will have the outlet terminated in a single gang work area outlet (WAO) on the nearest wall, column, or approved surface above ACT, within 15 feet of the proposed access point location. Use appropriate ceiling grid clips and suspension wire to secure access point to ceiling grid independently, depending upon if tile is flush or recessed. Patch cables must be installed to standards and be secured every 4' to 5' and kept 2 feet away from other ceiling mounted devices and a minimum of 1 foot away florescent light ballast, electrical lines and other EMI sources.

#### High Ceilings

Wall mounted WAP's using an Oberon mount should only be used in special instances and be pre-approved by ITS. One such case is when the ceiling height is above 12 feet. Extend a 1" conduit from above to a single gang WAO, with flat faceplate. An Oberon 1029-00 or equivalent will be installed around the WAO.

#### Solid and Open Ceilings

In new construction, conduit will be installed in areas with solid ceilings. Terminate conduit in a recessed single gang WAO. The access point will mount directly to the WAO and flush with ceiling, maintain a minimum distance of 2 feet from other ceiling mounted devices. Terminate in flat faceplates.

**6.9 Cameras:** Deployment of Security Cameras must follow ETSU's Policy, including but not limited to funding, design, installation, appropriation, use and feasibility. Camera placement and wiring on new or renovated buildings to be coordinated with ITS, Public Safety and the Security Camera Advisory Group prior to final design.

For new construction, a site visit must be arranged with ITS for the desired location and elevation. This visit shall occur after wall studs are installed and before drywall installation or external façade is complete. Install and design per manufacturer specifications. Cabling requirements for all cameras shall be two yellow-jacketed CAT6A cables terminated to two green CAT6A jacks.

## 6.10 Door Controls / Building Automation Systems (BAS):

BAS can consist of:

- M/E/P and Environmental monitoring and control
- Electronic Access Control (EAC) and/or Electronic Safety and Security (ESS)
- Or any system that Monitors/Controls/Operates/Manages building services

Cabling connecting BAS to the ETSU-ITS network must follow the standards of TIA/EIA-862-B and adhere to the installation methods and materials of this document. All cabling (fiber and copper) to be connected to ETSU's network must be certified and follow the standards and test methods of this document.

Network connectivity to the ETSU ITS network must meet the following criteria:

- Ethernet auto negotiate
- 1 MAC address per port (per cable)
- DHCP for IP addressing – reservations may be requested if a persistent address is required. Contact [itshelp@etsu.edu](mailto:itshelp@etsu.edu) for required forms.
- Network devices that extend or share connectivity such as switches and routers are prohibited.
- Special configurations such as Vendor Class Options and PXE will be considered on a case-by-case basis and may be granted if they do not interfere with other services.
- Special needs such as Firewall exemptions, VPN or DNS requests, require authorizations.
- All cases of network connectivity require one or more forms for authorization. Consult ETSU-ITS on appropriate documents required for review and approval (VPN/Statics/DNS/Security/etc.)

All non-ITS-supported equipment required for the function of access/BAS/etc. shall not be installed or housed inside ITS communication rooms. If ETSU network or Internet access is required by these systems, an approved network cable (or cables) shall be installed from the TR to a WAO nearest the serving BAS equipment or CPU with a NIC connection. Any proprietary cabling (non-ITS) connected to these systems must comply with the standards of this document and be installed in their own independent cabling supports and penetrations.

---

## SECTION 7 – FIRE STOPPING

---

Communication conduits and sleeves are meant to be re-entered numerous times over the life of the building. Firestop sizes and methods must meet the requirements of the Authority Having Jurisdiction and also be flexible enough for future moves, adds and changes for telecommunications. Firestopping *around* the conduits shall be elastomeric (permanent). Firestopping *inside* the conduit shall be pliable putty (removable). Conduits must be available for re-entry for future cabling. All rated penetrations shall be labeled at each accessible entry and exit (both sides of wall for wall penetrations or on wall near floor for floor penetrations). The installer of the assembly is responsible for obtaining, (prior to their procurement, fabrication and installation), official documentation from the AHJ that all materials intended for firestop thru-penetrations are approved. All rated sleeves and penetrations needed for delivery of communications cabling must meet, at minimum, the following requirements:

- Where rated walls, floors, roofs, ceilings and/or any other members are cut/penetrated to install cabling, pathways, or related components, the installer must provide and install all materials necessary to re-establish or exceed the original fire-rating of that structure (specified requirements), to the satisfaction of the authority having jurisdiction (SFMO or code official).
- Premanufactured firestop assemblies are permitted as long as they have been pre-approved (reviewed and stamped as approved) by the SFMO prior to installation.
- It is recommended that:
  1. All rated penetrations must have a computer-generated decal applied within 12 inches from the center of each penetration showing contractors name, address, phone, hour type and rating, and signed/dated by installer, and be clearly visible from floor level.
  2. The decal must be minimum 5"x7" in size, and it must be photographed in place by the contractor immediately upon installation.

NOTE: Although it is permissible for cabling insulating jackets and outer sheathes to be in direct contact with approved firestop compounds, the application of non-approved materials and coatings are not allowed at any time. This includes the direct (intentional or unintentional) application of paint to exposed cabling, etc. The installation contractor shall be responsible to replace all fire-proofing materials required for the installation. Any missing fire-proofing materials shall be reported to ITS for repair to maintain required fire rating of structure. Do not route cables through block wall without a sleeve, directly lay data cables on ductwork, piping and plumbing systems or on top of the lay-in ceiling tile. See NEC and BICSI for more information.

---

## SECTION 8 – FURNITURE, FIXTURES AND EQUIPMENT (FF&E)

---

See ETSU's Design Guidelines regarding communications infrastructure and furniture/equipment. No furnishings or equipment of any kind (including modular furniture systems) should be designed that block, cover, or impede full view and access to new or existing electrical and communication receptacles in walls or floors. All receptacles shall be unobstructed and labeling shall be in clear view for accessibility, future adds/changes, and E-911 compliance. NOTE: See Section 11 of this document for more labeling requirements.

Any furnishings designed to be installed against walls shall have either: 1) Fully open area below work surfaces (privacy panels) exposing the adjoining wall a minimum of 2'-0" AFF – preferably no privacy panels or backing against walls, or 2) a full sliding panel system below work surface height to allow for full view and accessibility to all power and communications outlets on wall. Note: This requirement is necessary regardless of whether permanent wall has existing outlets or not, for future growth and accessibility.

Telecommunications and Power distribution planning should be coordinated to avoid conflicting pathway assignments. Permanent cables shall be installed only in or on permanent walls or permitted poles. All modular furniture shall be fed from a work area outlet, MUTOA or "Consolidation Point" (CP). Horizontal cabling shall not terminate in modular furniture. Locate CP in an accessible area free from workstations and heavy file cabinets. Cabling from CP to modular furniture shall be through a service pole or through the wall if not blocked from furniture. Do not block access to horizontal cabling pathways or outlets.

---

## SECTION 9 - BONDING AND GROUNDING

---

### Telecommunications Main Grounding Busbar (TMGB)

- Locate TMGB in the facility utility entrance, as close as practical to the primary or secondary protectors and near the electrical panel to which it will be bonded.
- TMGB must be sized according to the anticipated number of bonded connections. Add 25% room for growth beyond needed design (pre-drilled lug holes, etc.).
- Building steel within 1.8 m [6 feet] of the communications grounding system should be bonded into the system. The Bonding Conductor for telecommunications (BC), connecting the TMGB to the IBT, must be sized at least one (1) size larger than TBB. Where practical, BC length should be less than 9 m [30 feet].
- Per TIA 607-D Standard, individual projects requiring larger conductor sizes or greater clamp density must take precedent over these guidelines. Each individual racks and cabinet must bond to the TGB with a conductor size of #6 AWG or larger. Serial connections (or "daisy-chaining") between racks, cabinets, enclosures, etc. will not be accepted. Bonding couplers connecting sections of cable tray are permitted.

### Bonding within Racks and Cabinets

- Racks and cabinets must have grounding busbars installed along one rail to provide effective bonding of rack / cabinet mounted equipment.
- Larger equipment (chassis switches) with integral grounding terminals must be bonded to the vertical busbar with equipment grounding conductor attached to those terminals and bonded to the rack-mounted busbars.
- Smaller equipment (servers, switches) not having integral grounding must be bonded from the rack grounding busbar to a grounding lug connected to an accessible equipment chassis metal screw (ensure the chassis paint is removed where the lug connects to ensure a good connection).

Note: See Detail 6 in the appendices section of the ETSU CDS Policy. In existing facilities where an adequate electric bonding system is already in place, the a TGB and TBB system is permitted to be properly bonded to it if it is inspected/observed for compliance by the Engineer or AHJ. All methods of the system must conform with Chapter 8 of the BICSI TDMM and ANSI/BICSI-N3-2020 for installation, testing and inspection (telecommunications bonding only).

## SECTION 10 - CABLE TESTING AND DOCUMENTATION

All test equipment must have been through recent factory authorized and documented calibration (within the last two years prior to testing in field). Paperwork should accompany tester giving evidence of such. Testing must commence only after all materials are 1) permanently installed, 2) permanently adjusted, 3) bonded and 4) correctly and permanently labeled. Testing must commence only in a clean environment, free of moisture, dirt, dust and debris.

NOTE: Labeling of all components must be accurate and officially final to be accepted. Labeling of devices, faceplates, bulkheads and other items will only be accepted by ETSU that reflect final and accurate room numbering in compliance with the University's numbering system for the facility and the Tennessee Board of Regents Physical Facilities Inventory and Survey (PFIS). It is the user's responsibility to obtain acceptance prior to any final labeling application.

No optical fiber or copper connectors, components or hardware having direct contact with cable strands may be re-used or re-terminated after one use.

### Optical Fiber Cable Testing

One-cord reference method is preferred for both Multimode and Single-mode links. Consult ETSU prior to testing MPO/Array links. All optical fiber methods and procedures must follow TIA-568.3-D and include at minimum:

- Test instruments that comply with Annex E.3
- Test measurements as specified in Annex E.4 and E.5

### OPTICAL FIBER TESTING METHODS

Optical Fiber Type	Testing Method per TIA-568.3-D (annex 'E')
Single-mode OSP	Tier 1 <u>and</u> Tier 2 testing required: <ul style="list-style-type: none"> <li>- Tier 1: Attenuation measurement for permanent link measured with optical loss test set (OLTS) <b>LSPM</b> using methods specified by TIA-526-7-A, method A.1 and TIA-568.3-D, annex 'E'.</li> <li>- Tier 2: Additional attenuation measurement with optical time domain reflectometer (OTDR) using methods specified by TIA-526-7-A, method B and TIA-568.3-D, annex 'E'.</li> </ul>
Single-mode ISP and Indoor-Outdoor	Tier 1 testing required (Tier 2 optional unless specified by ETSU): <ul style="list-style-type: none"> <li>- Tier 1: Attenuation measurement for permanent link measured with optical loss test set (OLTS) <b>LSPM</b> using methods specified by TIA-526-7-A, method A.1 and TIA-568.3-D, annex 'E'.</li> </ul>
Multimode ISP and Indoor-Outdoor	Tier 1 testing required (Tier 2 optional unless specified by ETSU): <ul style="list-style-type: none"> <li>- Tier 1: Attenuation measurement for permanent link measured with optical loss test set (OLTS) <b>LSPM</b> using methods specified by TIA-526-14-C, method B and TIA-568.3-D, annex 'E'.</li> </ul>

OPTICAL FIBER AND CONNECTOR ATTENUATION TABLE

Optical Fiber or Connection Type	Wavelength (nm)	Maximum Attenuation (dB/km)
OM1 – Multimode (grandfathered)* 62.5um per TIA 492AAAA	850	3.5
	1300	1.5
OM2 – Multimode (grandfathered)* 50um per TIA 492AAAB	850	3.5
	1300	1.5
OM3 – Multimode 850nm Laser-Optimized 50um per TIA 492AAAC	850	3.0
	1300	1.5
OM4 – Multimode 850nm Laser-Optimized 50um per TIA 492AAAD	850	3.0
	1300	1.5
OM5 – Multimode Wideband Laser-Optimized 50um per TIA 492AAAE	850	3.0
	953	2.3
	1300	1.5
OS1 – Single-mode (grandfathered)* Inside Plant per TIA 492CAAA	1310	1.0
	1550	1.0
OS1 – Single-mode (grandfathered)* Indoor-Outdoor per TIA 492CAAA	1310	0.5
	1550	0.5
OS1 – Single-mode (grandfathered)* Outside Plant per TIA 492CAAA	1310	0.5
	1550	0.5
OS1a – Single-mode Inside Plant per TIA 492CAAB	1310	1.0
	1383	1.0
	1550	1.0
OS2 – Single-mode Outside Plant per TIA 492CAAB	1310	0.4
	1383	0.4
	1550	0.4
CONNECTOR LOSS (per mated pair)	n/a	0.75
SPLICE (each)**	n/a	0.3

\*Per TIA-568.3-D, Annex B – Fibers and cable types within this annex (noted above) are grandfathered and are not to be used for new installations. These cable types shall only be installed at the request of ETSU-ITS as replacement media for legacy systems.

\*\*Optical fiber splices must be measured in accordance with TIA-455-78-C for field testing.

Use of Test Cords

Per TIA-568.3-D 7.3.4, there is a recommendation (but not requirement) for the use of reference-grade terminations on test cords to reduce uncertainty and improve the reproducibility of measurements. Reference-grade terminations result in lower loss than standard-grade terminations. The table below provides the test cord loss allowance for two different termination combinations:

Mated termination combination	Multimode (dB/connection)	Single-mode (dB/connection)
Reference-grade to Standard-grade	0.3	0.5
Standard-grade to Standard-grade	0.75	0.75



## Supportable Distances and Channel Attenuation (Link Loss Budgets)

Per BICSI TDMM Chapter 11, link attenuation (link loss budget) is calculated as:

Link attenuation = cable attenuation + connector attenuation + splice attenuation

Cable attenuation (dB) = Attenuation coefficient (dB/km) x length (km or percent of km as applicable)

**NOTE:** The contractor must ensure the proper usage of optical fiber patch cords during testing, having the correct core-to-cladding offset on connected fiber. (i.e. 50µm-to-50µm, not 50µm-to-62.5µm for multimode where specified, etc.) Test results must show calculated loss budget for each fiber length and type. The use of mode-conditioned launch cables and fiber mandrels must be employed where applicable. All color coding must comply with TIA-598-D Optical Fiber Color Coding. See more test results requirements at end of next section.

## **Copper Cable Testing (Balanced Twisted-Pair)**

### Category 5e/6/6A Cabling

Each communications 8P8C outlet/jack must be tested for performance, conductor integrity, and termination sequence. Testing must be performed over the 'Permanent Link' between modular jacks in the work areas, and modular ports on the patch panels.

Provide connectorized testing of each outlet under ANSI/TIA 568.2-D Section 6 specifications for each cabling category, using approved and calibrated test equipment. Calibration shall be done annually as approved by the manufacturer. Every wire and connector pin for each cable from an outlet to the patch panel or distribution frame must be tested for the following at the specified frequencies as applicable. Some tests are optional as noted unless specified by ETSU.

- Wire Map
- Length
- Insertion Loss (Attenuation)
- NEXT Loss, pair-to-pair
- FEXT Loss. Pair-to-pair
- PSNEXT Loss
- ELFEXT Loss, pair-to-pair
- PSELFEXT Loss
- Return Loss
- Propagation Delay
- Delay Skew
- PSAACRF
- DC Loop Resistance
- DC Resistance Unbalance within a pair (CAT6A)
- DC Resistance Unbalance between pairs (CAT6A)
- TCL/ELTCTL (if required by manufacturer for warranty, informational only or CAT6A)
- ACRF, AFEXT, ANEXT, PSAFEXT, PSAACRF, PSANEXT, PSAACRF (CAT6A)

Per ANSI/TIA-1152, any *fail* or *fail\** must result in an overall fail. In order to achieve an overall pass condition, all individual results must be *pass* or *pass\**. Follow the manufacturer's warranty submittals and submit a copy of all results (including UTP/STP/ScTP, CATV, and Optical Fiber) to ETSU before final certification. Test results must be provided in the following Sections, Format and Order\*:

Section 1: Cover sheet clearly indicating project name / number and date of testing. Include name and signature of qualified technician(s) that performed the testing.

Section 2: Summary sheet with a single table indicating all ID's in alphanumeric order, total cable quantity and a pass or fail result for each.

Section 3: Individual sheets for each individual twisted pair cable or optical fiber strand pair in order showing all applicable test results per TIA standards, including plotted graphical data.

\*Test results submitted in any other format will be rejected.

- Balanced twisted-pair cable test results must be submitted in their original format from tester (\*.filetype) as well as PDF format for Sections 1 through 3 above. Twisted-pair testing limits must conform to TIA-568.2-D for the permanent link.
- Coaxial cable test results must comply with TIA-568.4-D. Provide test results on a document (PDF spreadsheet) indicating all stated measurements in sections 6 through 8 of TIA-568.4-D.
- Optical fiber test results must be submitted in the format as specified in TIA-568.3-D, Annex E.6 and shall include all seven items for Tier 1 test results and all nine items for Tier 2 test results.

---

## SECTION 11 - SUBMITTAL REQUIREMENTS / SHOP DRAWINGS

---

Submittals play a critical role at ETSU. During installation, submittals confirm the installer has met the owner's intent. After installation, they serve as part of the as-built resource and O&M manuals.

All submittals must be provided to ETSU in their entirety in both printed and PDF formats. Note: See "Submittals Checklist" in this document.

### 11.1 Submittals due prior to installation:

Communication Submittals are required to be provided to ETSU for all materials to be provided/installed/fabricated. All submittals must be approved by both the designer (sealed as "approved") and ETSU prior to acquisition, installation or construction:

- Provide cover sheet showing project number, name, and description. Include table of contents with all product names, manufacturer, and specific product number identified with an arrow. No highlighted submittals will be accepted.
- Labeling samples of faceplates/enclosures/patch panels/OSP items showing compliance with ETSU-ITS requirements.
- Provide shop drawings (scaled plan and elevation drawings) of the proposed layout and construction of all components in all communications rooms indicating locations of busbars, racks, enclosures, sleeves, ladder rack, service loops, wall mounted equipment, etc. These proposed layouts must be approved by the Designer and ETSU prior to construction.

### 11.2 Submittals due at Substantial Completion:

Record Drawings (as-built drawings)

- Provide scaled drawings indicating actual location of the TR's, data outlet locations, Wi-Fi outlets, camera outlets, floor boxes and poke-through assemblies, and any above-ceiling terminations and service loops. Also, to be included are all communications outlets and other points of termination including all outlet labeling and identification. Provide scaled CAD drawings (.dwg) and PDF drawings of floorplans, risers, OSP, site and all other drawings to reflect as-constructed conditions, including conduit to-and-from data.
- A copy of the application for manufacturer warranty as submitted to the manufacturer – contact ETSU-ITS for specific requirements in their policy.

Note: Submittals for product or manufacturer substitutions must be submitted to ETSU ITS for approval prior to construction or installation. The submittals must include full specifications and warranties and verified with a recognized independent testing laboratory such as UL or ETL. All substitutions must be approved by the Designer and ETSU in writing. A full mock-up is required to be submitted and approved on patch panel and faceplate labeling prior to any work.

## SECTION 12 - LABELING

Accurate and correct labeling is critical so the information can assist in a 911 data base. At minimum, all faceplates, jacks, patch panels, termination blocks, conduit endpoints, trays, backbone cables, enclosures, racks, cabinets, and grounding shall be labeled according to ANSI/TIA 606-B, Class 3 standards, with specific labeling scheme of ETSU ITS. All labeling material, methods and scheme shall be submitted during the required submittal process. All labels shall be printed or generated by a mechanical device and intended for use and environment type. Labeling is to include:

- Identifiers required in class 3 administration
- "Caution Fiber Optic" adhesive marker every HH. Label to include SM & MM fiber count and "to and from".
- OSP cables shall be labeled with permanent and neat penmanship in every HH and EF with "to and from" and cable pair count.

In all ISP environments (WAO's, TR's, racks, pathways, etc.), labels shall be:

- Self-laminating (smudge proof)
- Designed for use from the manufacturer – not a third-party supplier (Avery, etc.)
- Self-adhesive
- Black fonts on white tape
- Patch Panels and Faceplates shall be labeled by Brady ID Pro, with 14-point font – spacing of 0.7 (see below)

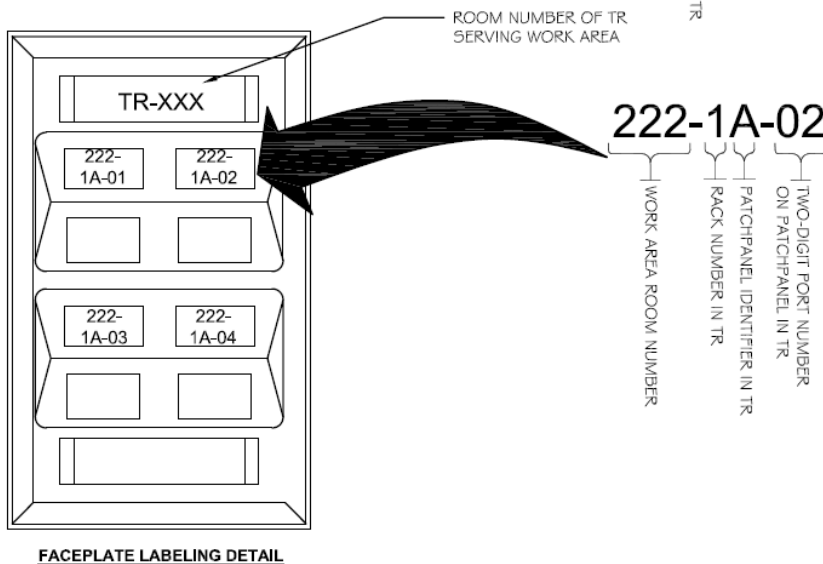
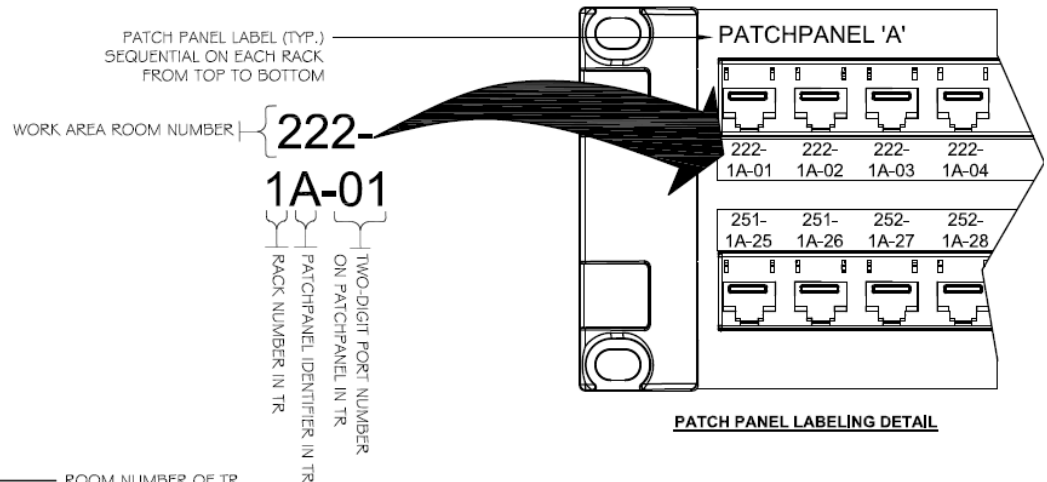

\* FOR INFORMATIONAL PURPOSES ONLY

---

## APPENDIX A – SUBMITTALS CHECKLIST

---

(Sample list based on ETSU-ITS typical items)

NOTE: all manufacturer submittals/cutsheets must have arrows clearly indicating each individual chosen part number for approval. Submittals not in compliance with this will be rejected and required to be resubmitted.

### **COMMUNICATIONS CABLING**

- Balanced twisted-pair horizontal cable (5E/6/6A)
- Balanced twisted-pair backbone cable (3+)
- Fiber Optic OSP Cable
- Fiber Optic Riser Cable (indoor/outdoor)
- Coax Horizontal Cable (RG6)
- Coax Riser Cable (RG11)
- OSP Coax, Flooded
- OSP Twisted pair
- Innerduct (detectable/color coded)

### **OUTLETS, CONNECTORS AND BULKHEADS**

- Office Faceplate (match approved electrical color)
- Classroom Faceplate (match approved electrical color)
- Student Room Faceplate (match approved electrical color)
- Student Room CATV Faceplate (match approved electrical color)
- Modular Furniture Faceplate (match approved electrical color)
- Blank Faceplate inserts
- Wi-Fi/WAP surface outlet box
- Modular jacks (5E/6/6A)
- Coax RG6 F-Fittings
- Coax RG11 Fitting
- Coax .500 Fitting
- Coax .750 Fitting
- Fiber Optic fan-out kits
- Fiber Optic Connectors
- Fiber Optic Bulkheads
- Outlet Cut-In Brackets

### **PATCHPANELS, HOUSINGS AND TERMINAL BLOCKS**

- Loaded or Unloaded Patch Panels (5E/6/6A)
- 110 Blocks w/clips
- Fiber Optic Wall Mount Housing
- Fiber Optic Rack Mount enclosure
- Twisted-pair OSP Building Entrance Terminals
- Twisted-pair OSP Surge Protection Modules

### **EQUIPMENT RACKS AND ACCESSORIES**

- Equipment Racks
- Equipment Cabinets
- Rack Base Insulator Kit
- Horizontal and Vertical Wire Management
- Rear Cable Strain Relief Bar
- Cable Tray, (for TR/AV rooms)
- Cable Tray, (for corridors and common areas)
- Cable Tray Ground Strap Kit
- J-Hooks/Independent supports
- Telecommunications Bonding Busbar (TGB/TMGB)
- Rack-mount ground bar

### **MISCELLANEOUS ITEMS**

- Manufacturer 'Certified Installer' Certificate
- Outlet/Patch Panel Labeling Scheme and mock-ups
- BICSI RCDD Certificate
- Test Equipment Mfr & Calibration statement
- Firestop Materials and Sleeve Kits
- Fire Retardant Paint and/or additive
- Detectable OSP Warning Tape
- Emergency Phone
- OSP Handhole/Vault/Pull Box
- Splice Enclosures
- Duct Seal
- Smart Conduit Body LB Assembly
- Floor In-slab Box Assembly w/components
- Floor Poke-through Assembly w/components

**What is an ETSU-ITS variance?**

A variance is an allowable deviation from specific requirements of a published standard where a proposed alternate material, method, or concept will provide equal or higher safety, reliability, redundancy, and technical objectives. This variance is strictly within the bounds of ETSU-ITS methods and materials and does not apply to any other category of installation of construction design, materials or methods.

**What does a variance cover?**

If the variance is granted, it is limited to the particular site, scope, and area covered in the application and will not be considered as a precedent for other installations.

**What will a variance not do?**

A variance will not avoid compliance with the intention of a standard section or rule. A variance is not a method to recover or correct an installation or design error. A variance will not be granted if the alternate method would reduce the safety, effectiveness, or technical objective of the installation or equipment.

**Who may apply for a variance?**

Entities responsible for installation compliance with this document may apply for a variance.

**Who grants a variance?**

A variance for cabling installation may be granted only by ETSU-ITS upon written request.

(see variance form on next page)

## ETSU-ITS Telecommunications Standards Variance Request Form

(Complete and submit to ETSU ITS, who will either accept, modify or deny the variance and will notify the ETSU Project Coordinator)

Date of Request: \_\_\_\_\_  
Project Name: \_\_\_\_\_  
Job Number: \_\_\_\_\_  
Requester Name: \_\_\_\_\_ Company: \_\_\_\_\_  
Title: \_\_\_\_\_ ETSU Project Coordinator: \_\_\_\_\_

Reason for Request:  
\_\_\_\_\_  
\_\_\_\_\_  
\_\_\_\_\_  
\_\_\_\_\_  
\_\_\_\_\_

Is the variance requested due to (check all that applies?)

Cost \_\_\_\_\_ Amount \$ \_\_\_\_\_ Schedule Impact \_\_\_\_\_ Days impacted \_\_\_\_\_  
Other: \_\_\_\_\_ Reason \_\_\_\_\_

Suggested Alternate(s): (Attach drawings, descriptions, cut sheets etc. as necessary)  
\_\_\_\_\_  
\_\_\_\_\_  
\_\_\_\_\_  
\_\_\_\_\_  
\_\_\_\_\_

.....

To be completed by ETSU ITS  
Comments and or suggestions:  
\_\_\_\_\_  
\_\_\_\_\_  
\_\_\_\_\_  
\_\_\_\_\_  
\_\_\_\_\_

This request has been (circle):     Approved                       Modified                       Denied

Authorized Signature \_\_\_\_\_ Date: \_\_\_\_\_

---

## APPENDIX C – WARRANTY REGISTRATION (SAMPLE)

---

NOTE: Check with Hubbell for latest warranty form(s) prior to submission.

### Registration for Installation Warranty Mission Critical®

Please upload all information to the CI Portal: <https://hubbellwiringsystems.com/installercorner> You will need your Certified Installer Account Number and be registered on the portal to submit your Warranty.

Complete the Certified Installation Company Information section with your company's information and the names of those who designed the system.

Enter the Hubbell Cable used under the Warranty Information section.

Complete the Project Information section with the project name, end user company or organization name, project address, project contact person and his/her phone number and email address. *Please note the End Users are not required to sign the document the Certified Installer will the required signature.*

Complete the Products Installed: Part Number and Description.

Complete both the Horizontal Schematic and Backbone Schematic.

Upload Test Results using the following instructions:

***Original raw data tester file(s) only. Do not convert the test results into another format. PDFs, will only be accepted if approved prior, PDF files will need to be saved as compressed zip folder.***

**This is applicable for copper cable testing for Category 5e, Category 6 and Category 6A.**

#### Approved Testers:

Fluke Networks: DSX-5000 and DSX-8000 Series

Ideal: LanTEK 3

Ideal: LanTEK 4

PSiber: LanExpert 85

AEM: TestPro CV100

Softing: WireXpert 4500

LanTEK IV

*It is recommended that test results software be kept current. Download the most recent software version via the field tester manufacturer's website. Include all optical fiber test results (if applicable) from a power meter with an accuracy of + .5 dB or better in its original tester format. Do not convert the test results into another format. Test results for Backbone cables should also include the allowable attenuation values calculated using the link attenuation equation.*

### SUBMITTING WARRANTY INFORMATION

1. From the Warranty menu drop-down, select 'Submit Warranty Information.'
2. Fill out all the required fields in the 4-step submission form. You may click 'Save and Continue Later' at any time. You will receive a generated link you can use to take you back to where you left off.
3. On the last page you will upload your test results and submit. Leave any notes for our Mission Critical Coordinator in the Comments field.
4. Upon submitting you will get an email notification with a copy of the form for your records. If you find you have made a mistake, you can visit the 'Warranty Submissions' page. Here you can review and edit your submission, up until it has been approved by our coordinator.
5. Once it has been approved, you will receive an email with your Warranty Agreement. The agreement must be signed and emailed back to our coordinator.
6. After it has been signed and returned, you will then receive an email with your Warranty Certificate.

**For any questions or issues please contact our Mission Critical Coordinator: Jennifer Jovia @ [jjovia@hubbell.com](mailto:jjovia@hubbell.com)**